

**SPECIFICATION SHEET**

**JFW MODEL 50DR-046**

**DUAL ROTARY ATTENUATOR**

JFW Industries, Inc.  
Phone: 317-887-1340  
sales@jfwindustries.com  
www.jfwindustries.com

Frequency Range DC-2500 MHz

Impedance 50 Ohms nominal

Attenuation Range 0-50 dB in 1 dB steps

VSWR 1.2:1 maximum DC-500 MHz  
1.4:1 maximum 500-1000 MHz  
1.5:1 maximum 1000-2500 MHz

Insertion Loss 0.6 dB maximum DC-1000 MHz  
1.1 dB maximum 1000-2500 MHz

Attenuation Accuracy ± 0.2 dB or 1% DC-500 MHz  
± 0.3 dB or 3% 500-1000 MHz  
± 0.4 dB or 3% 1000-2500 MHz  
(whichever is greater)

RF Input Power 2 Watts average  
1000 Watts peak

Direction of Rotation Attenuation increases in a Clockwise direction

Indexing 30 degrees with stops at Minimum and maximum

RF Connector BNC, TNC, N or SMA female

Operating Temperature Range -20°C to +85°C

Lifetime 500,000 attenuation steps (each knob)

Knob/Panel Mounting Drawing 092-8435-02

Outline Drawings 092-1513-06 (50DR-046 BNC)  
092-5280 (50DR-046 TNC)  
092-440-06 (50DR-046 SMA)  
092-327-06 (50DR-046 N)

ECR/ECN #	DATE	REV	APPR / DATE	ECR/ECN #	DATE	REV	APPR / DATE
9999	05/12/2003	A	BAC 02/05/2004	22057	10/26/2012	D	TRS 10/26/2012
13697	12/20/2006	B	CLK 12/20/2006	25776	09/29/2015	E	TRS 09/29/2015
17251	05/26/2009	C	TRS 05/26/2009	28157	10/05/2017	F	TRS 10/05/2017

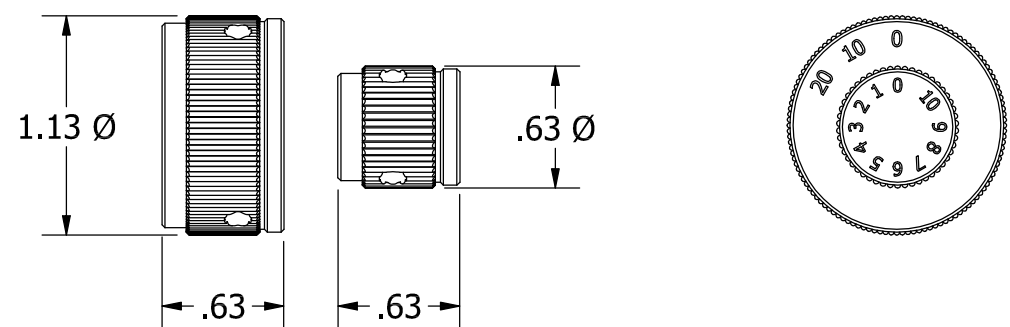
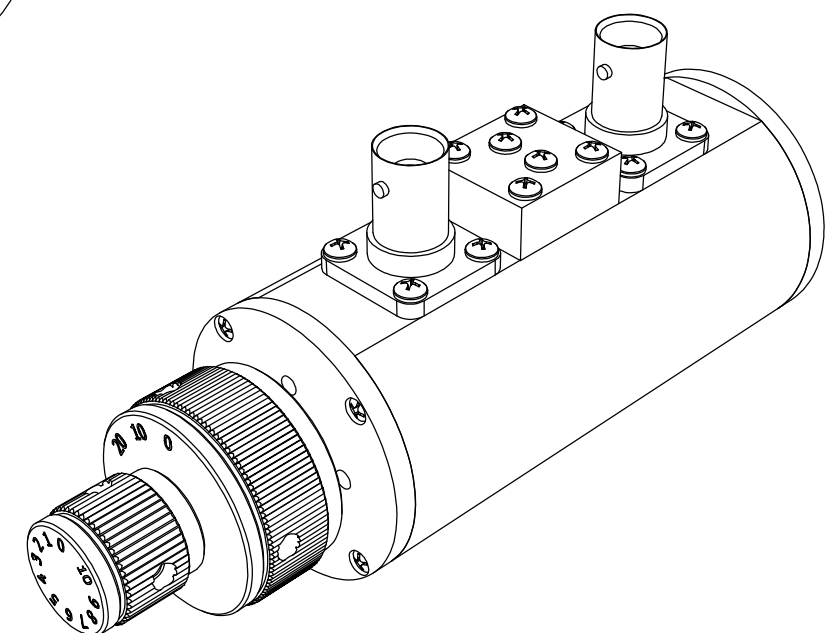
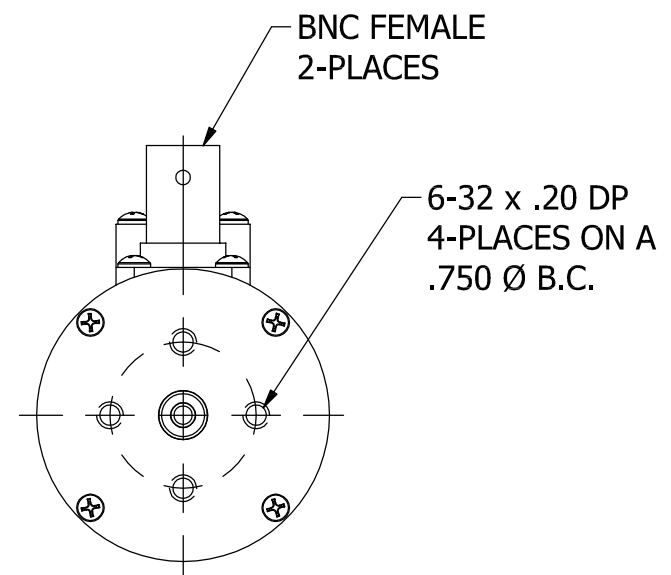
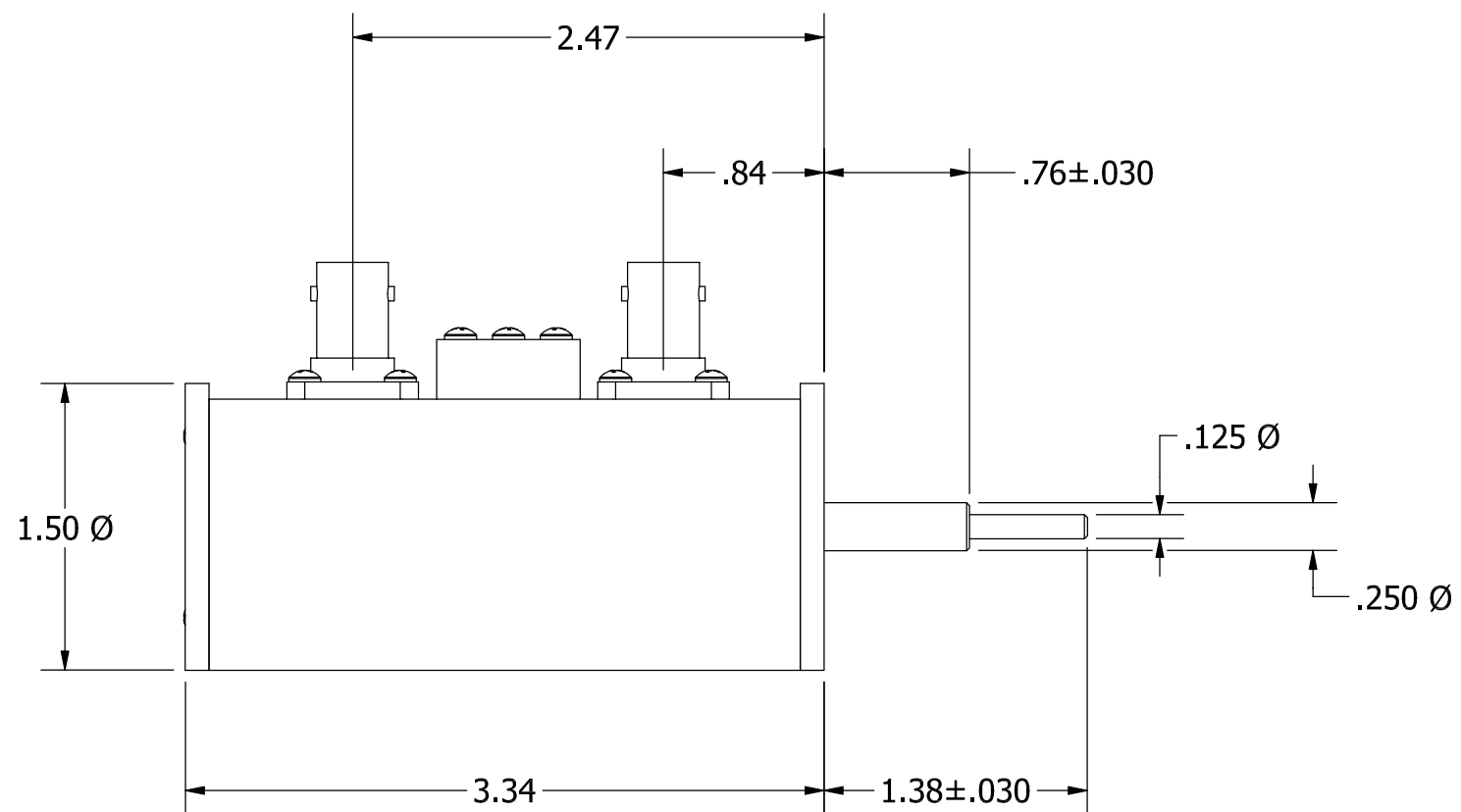

**KNOB DETAIL**

REV	ECN	DATE	BY	APPR
-	ISSUED	4-9-08	TEZ	TRS
A	24444	9-17-15	JZ	TEZ

		<b>JFW INDUSTRIES, INC.</b> <a href="http://www.jfwindustries.com">www.jfwindustries.com</a>		PH: 317-887-1340
		MATERIAL ALUMINUM ALLOY		PROPRIETARY INFORMATION
FINISH CHEMFILM TCP		MODEL 50DR-XXX		SCALE FULL
DESCRIPTION 0-30dB ROTARY ATTEN.		TOLERANCES .XX±.010 .XXX±.005 XX°±.5°		DWG # 092-5760

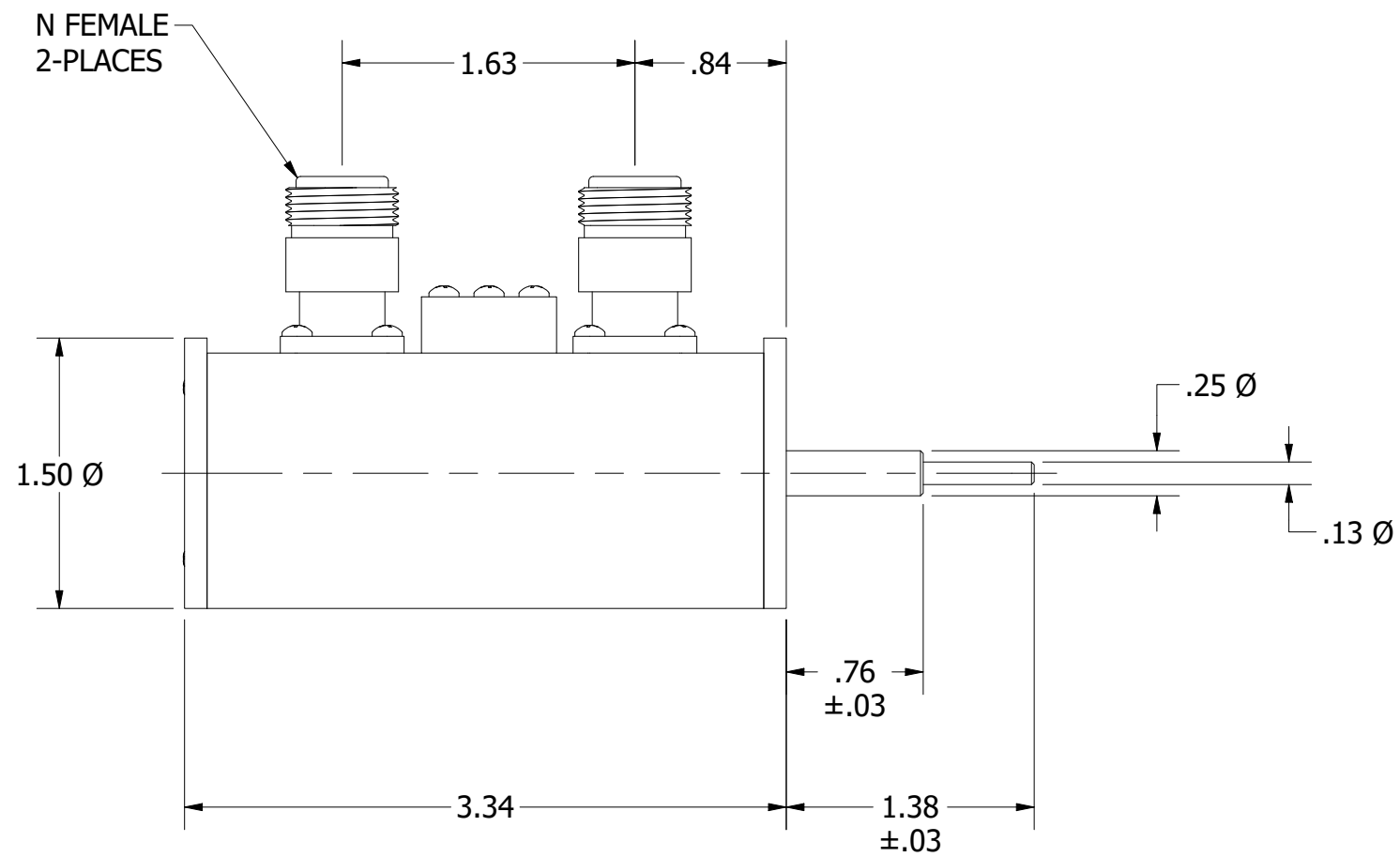

6-32 x .20 DP  
4-PLACES ON  
A .750 Ø B.C.

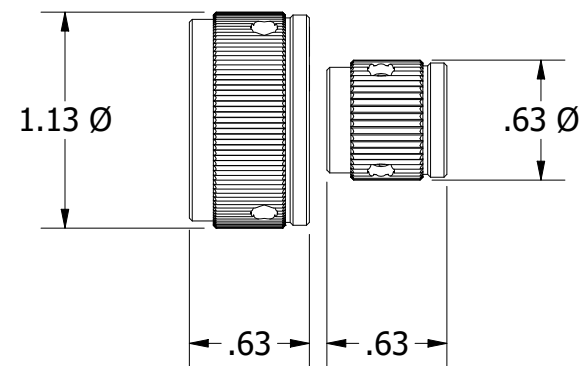
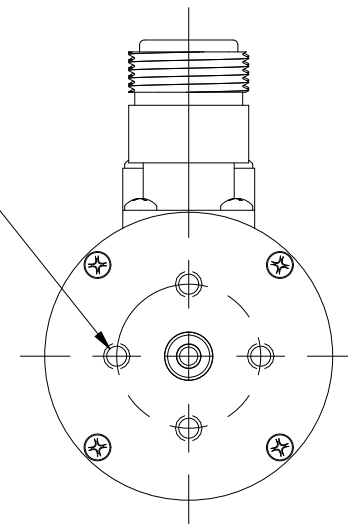

Knob Detail

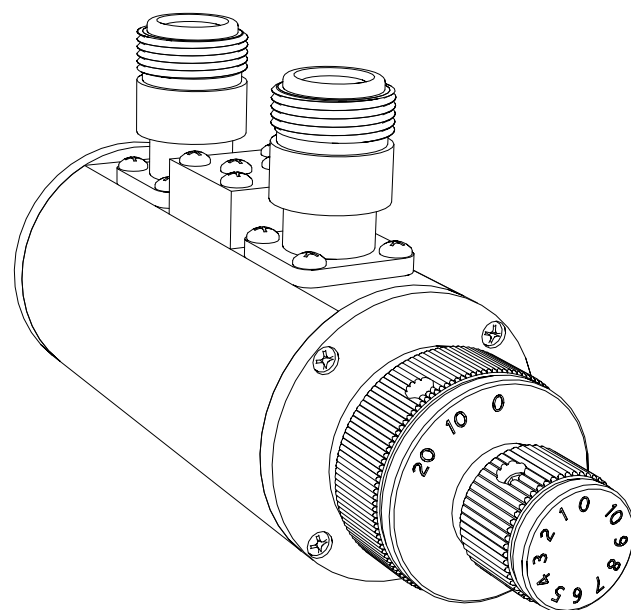

REV	ECN	DATE	BY	APPR
-	ISSUED	9-22-10	TEZ	TEZ
A	24444	9-18-19	GM	TEZ



**JFW INDUSTRIES, INC.**

www.jfwindustries.com

PH: 317-887-1340

MATERIAL	ALUMINUM ALLOY	PROPRIETARY INFORMATION
FINISH	CHEMFILM TCP	ALL SURFACES ARE TO BE FREE OF BURRS, PITS & SCRATCHES
MODEL	50DR-XXX	TOLERANCES
DESCRIPTION	ROTARY ATTENUATOR	.XX±.010 .XXX±.005 XX°±.5°
		DWG #
		092-6720

SCALE FULL

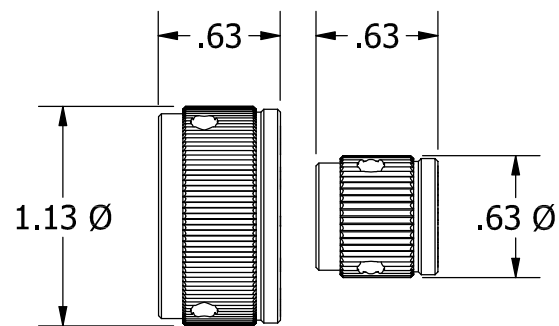
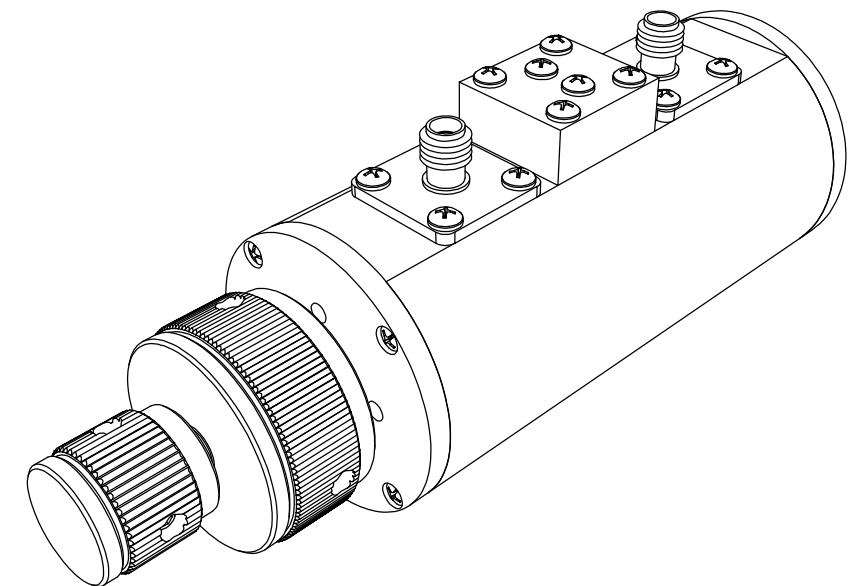
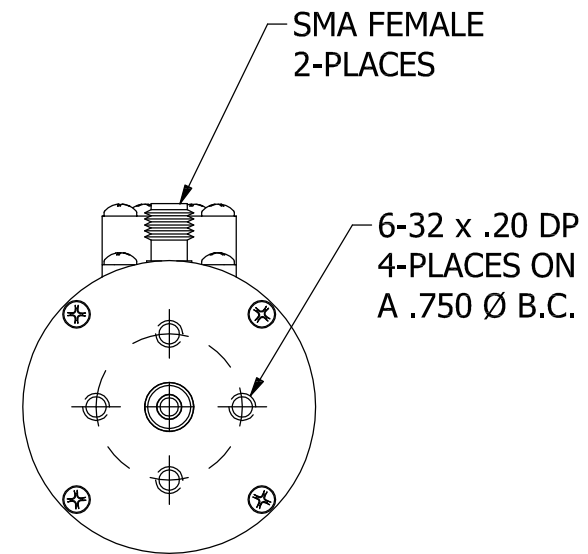
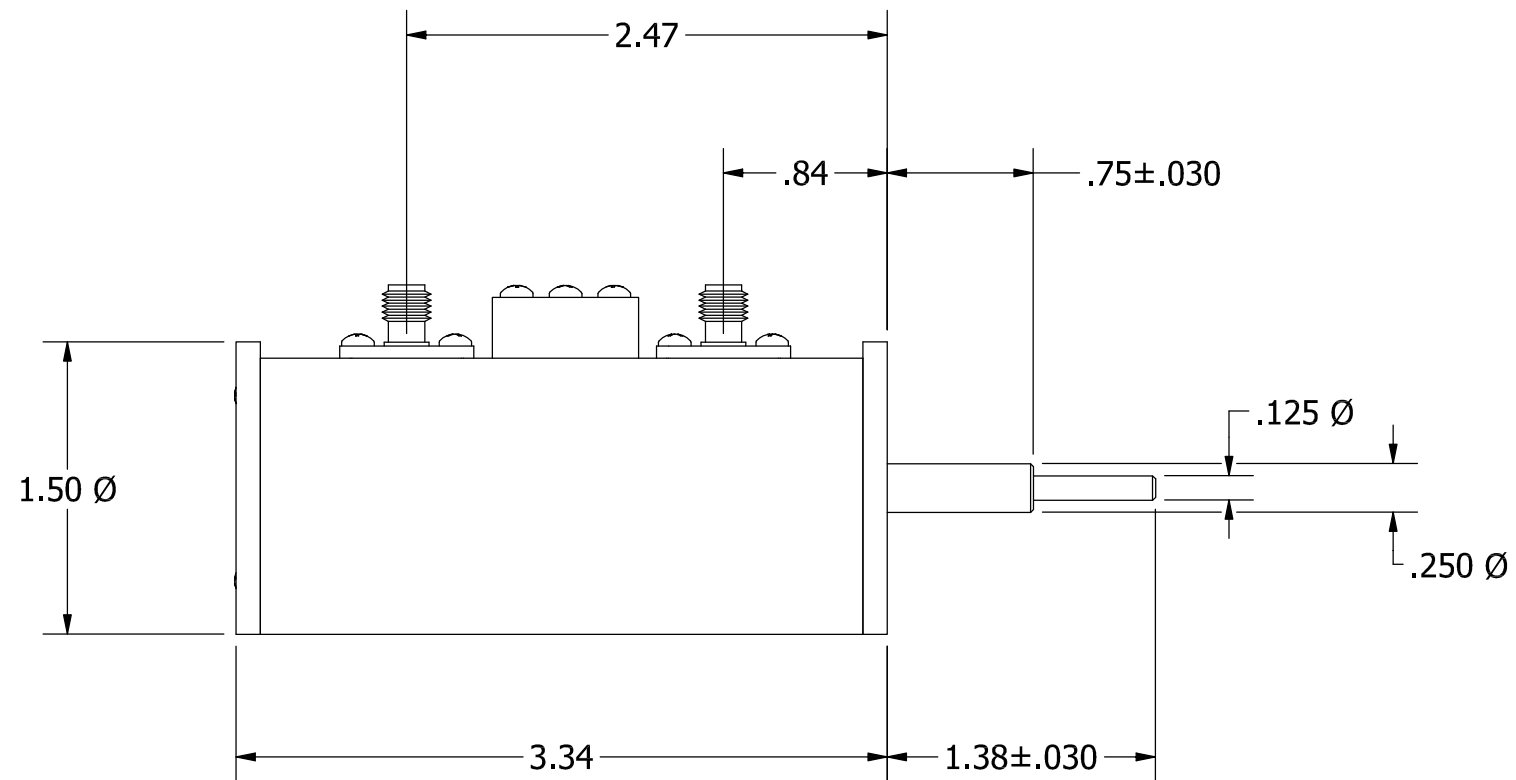

KNOB DETAIL

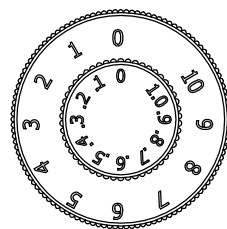

0-11 x 0.1 MODELS

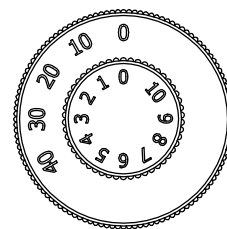

0-50 x 1 MODELS

REV	ECN	DATE	BY	APPR		
-	ISSUED	11-2-92	TEZ	FDW		
A	3934	4-15-93	TEZ	FDW		
B	6166	1-19-00	TEZ	FDW		
C	6594	1-24-01	CDJ	TEZ		
D	6750	6-11-01	CDJ	TEZ		
E	12635	4-20-06	ETW	TEZ		
F	23329	10-3-13	JZ	TEZ		
G	24444	11-24-15	JZ	TEZ		
					<b>JFW INDUSTRIES, INC.</b>	
					<i>www.jfwindustries.com</i> PH: 317-887-1340	
					MATERIAL	ALUMINUM ALLOY
					FINISH	CHEMFILM TCP
					MODEL	50DR-XXX
					SCALE	FULL
					DESCRIPTION	ROTARY ATTENUATOR
					PROPRIETARY INFORMATION ALL SURFACES ARE TO BE FREE OF BURRS, PITS & SCRATCHES TOLERANCES .XX±.010 .XXX±.005 XX°±.5° DWG #	
					092-1919	

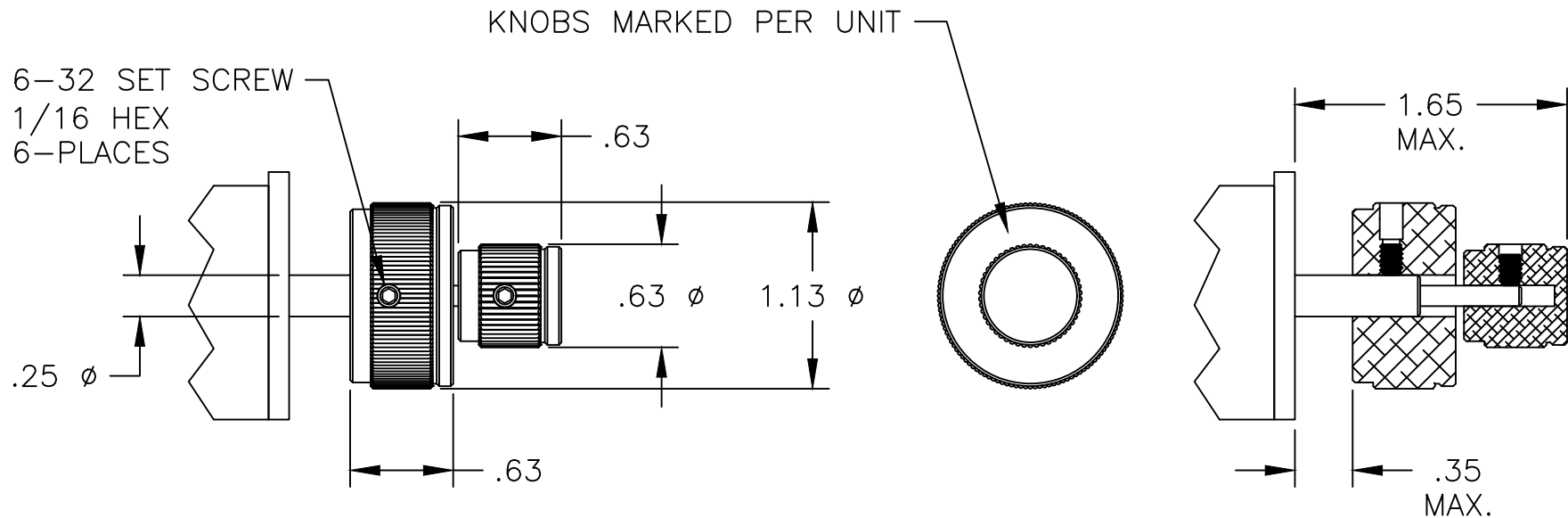

NOTE: PANEL THICKNESS IN ADDITION TO SCREW HEAD MUST NOT EXCEED .35 INCH MAXIMUM.

SET SCREWS FOR SMALL KNOB: 6-32 x 3/16 WITH 1/16 HEX HEAD (JFW #027-318)

SET SCREWS FOR LARGE KNOB: 6-32 x 5/16 WITH 1/16 HEX HEAD (JFW #027-319)

REV	ECN	DATE	BY	APPR				
-	ISSUED	9-24-2015	JZ	TEZ	 <b>JFW INDUSTRIES, INC.</b> www.jfwindustries.com      PH: 317-887-1340			
A	28025	8-14-2017	DTS	TRS				
					MATERIAL	ALUMINUM ALLOY	PROPRIETARY INFORMATION	
					FINISH	BLACK ANODIZE		ALL SURFACES ARE TO BE FREE OF BURRS, PITS, & SCRATCHES
					MODEL	132-002 & 132-003	SCALE FULL	TOLERANCES
					DESCRIPTION	ROTOR KNOB MOUNTING		.XX±.010 .XXX±.005 XX±.5'
							DWG #	092-8435-02