

SPECIFICATION SHEET

JFW MODEL 50DR-063

DUAL ROTARY ATTENUATOR

JFW Industries, Inc.
Phone: 317-887-1340
sales@jfwindustries.com
www.jfwindustries.com

Frequency Range DC-1100 MHz

Impedance 50 Ohms nominal

Attenuation Range 0-50 dB in 1 dB steps

VSWR 1.2:1 maximum DC-500 MHz
1.4:1 maximum 500-1100 MHz

Insertion Loss 0.5 dB maximum

Attenuation Accuracy ± 0.5 dB DC-500 MHz
± 1.0 dB 500-1100 MHz

RF Input Power 2 Watts average
1000 Watts peak

Direction of Rotation Attenuation increases in a Clockwise direction

Indexing 30 degrees with stops at Minimum and maximum

RF Connector BNC, N, SMA or TNC female

Operating Temperature Range -40°C to +85°C

Lifetime 500,000 attenuation steps (each knob)

Altitude 10,000 feet above sea level (operating)
40,000 feet above sea level (storage)

Knob/Panel Mounting Drawing 092-8435-02

Outline Drawing 092-1919 (50DR-063 SMA)

ECR/ECN #	DATE	REV	APPR / DATE	ECR/ECN #	DATE	REV	APPR / DATE
9999	05/12/2003	B	TRS 03/05/2004	23741	02/11/2014	E	TRS 02/11/2014
18362	03/05/2010	C	TRS 03/05/2010	25776	09/28/2015	F	TRS 09/29/2015
22213	12/04/2012	D	TRS 12/04/2012	28157	10/05/2017	G	TRS 10/05/2017

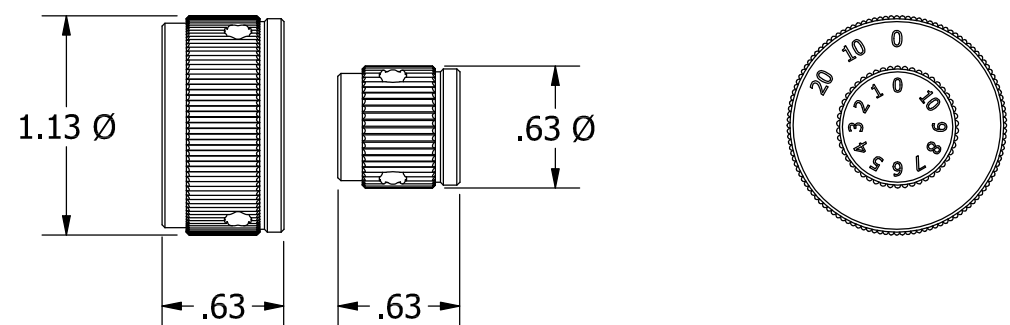
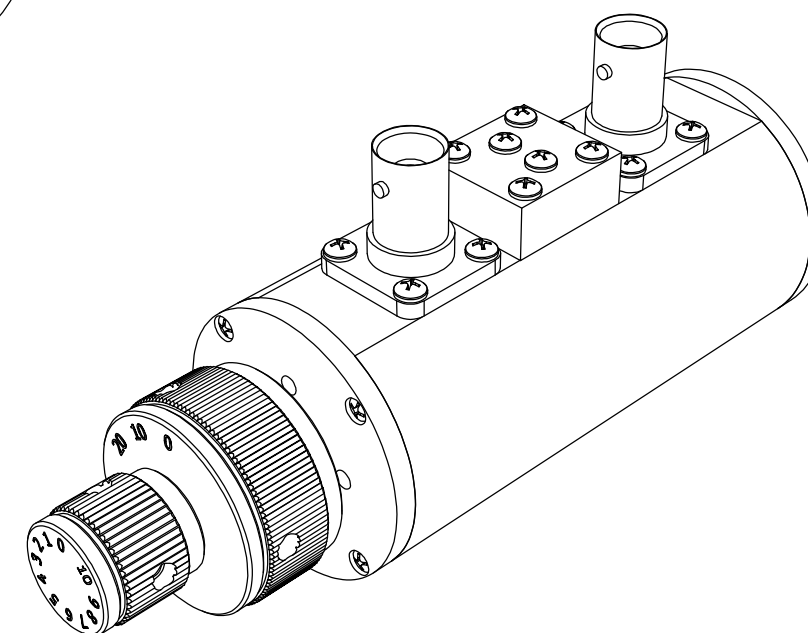
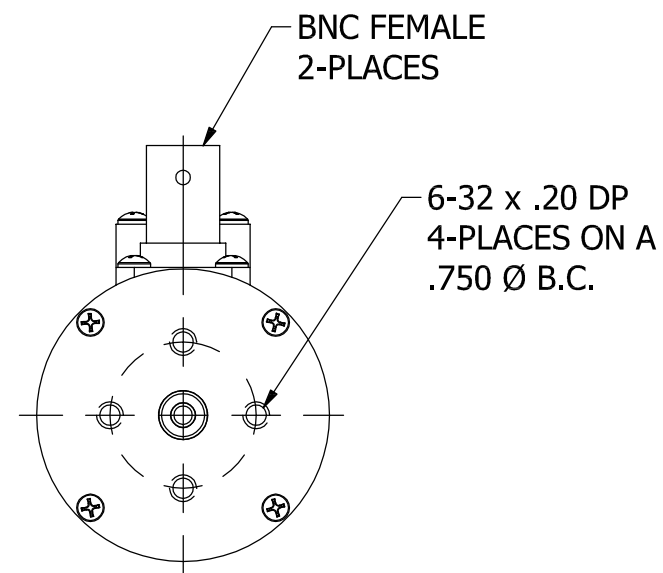
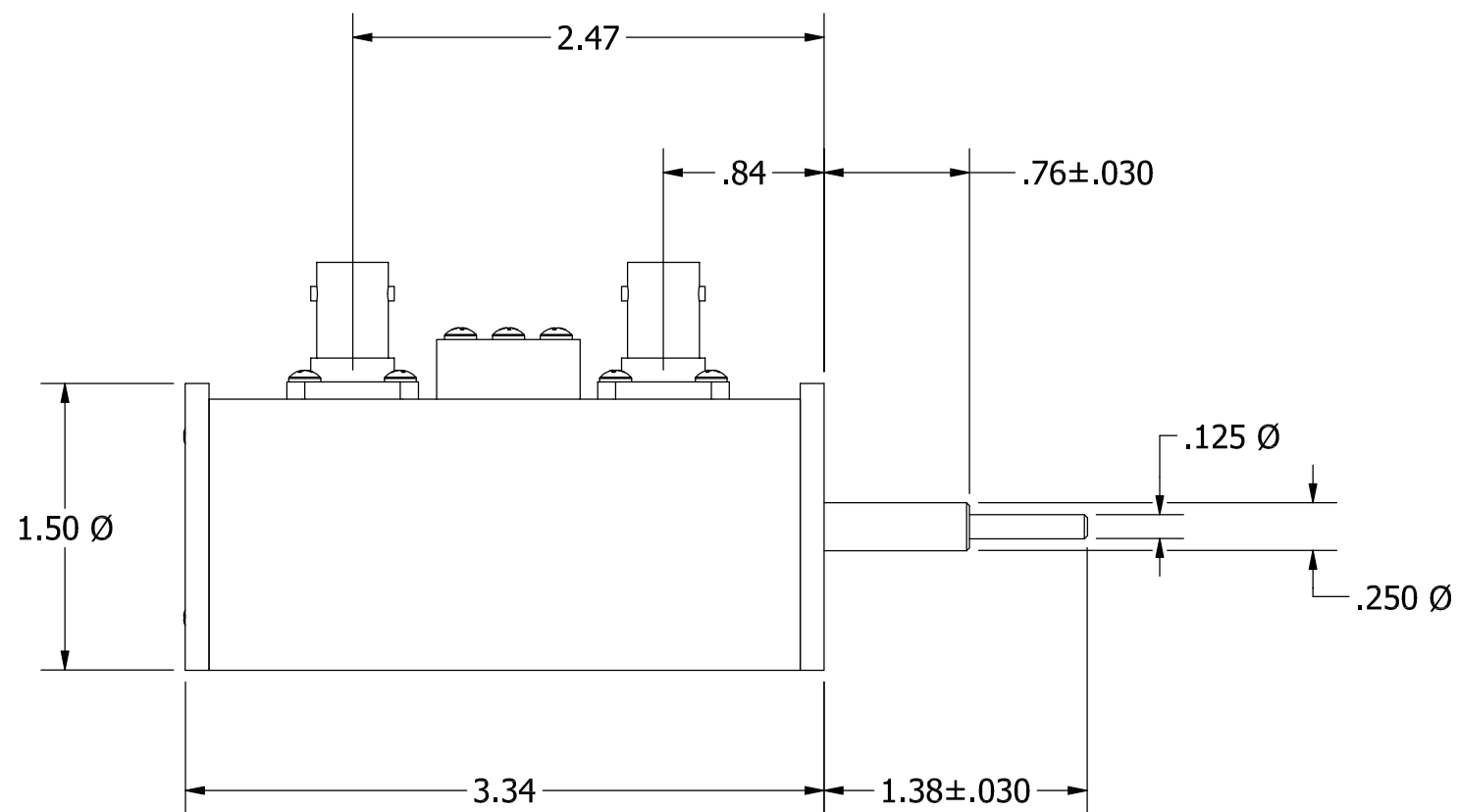

KNOB DETAIL

REV	ECN	DATE	BY	APPR
-	ISSUED	4-9-08	TEZ	TRS
A	24444	9-17-15	JZ	TEZ

JFW INDUSTRIES, INC.
www.jfwindustries.com PH: 317-887-1340

MATERIAL	ALUMINUM ALLOY	PROPRIETARY INFORMATION
FINISH	CHEMFILM TCP	ALL SURFACES ARE TO BE FREE OF BURRS, PITS & SCRATCHES
MODEL	50DR-XXX	SCALE FULL TOLERANCES .XX±.010 .XXX±.005 XX°±.5°
DESCRIPTION	0-30dB ROTARY ATTEN.	DWG # 092-5760

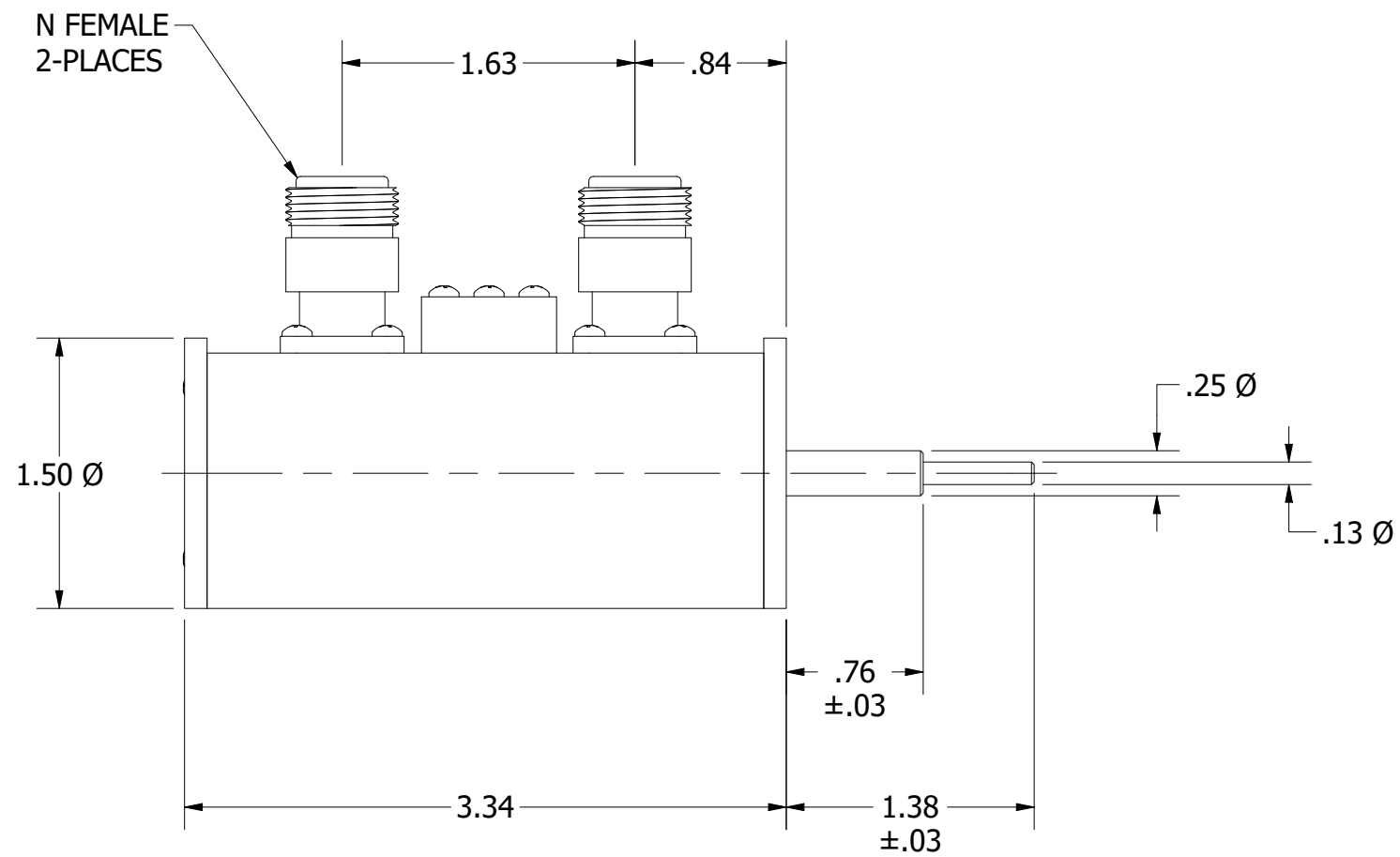

6-32 x .20 DP
4-PLACES ON
A .750 Ø B.C.

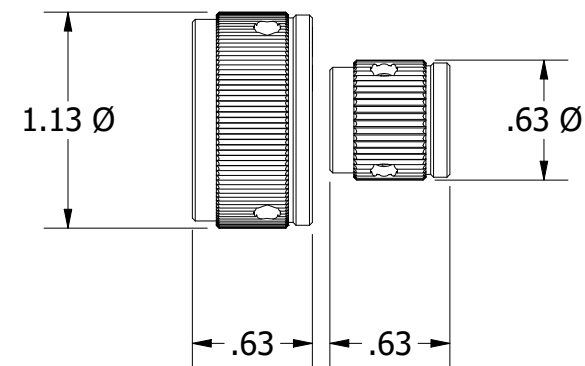
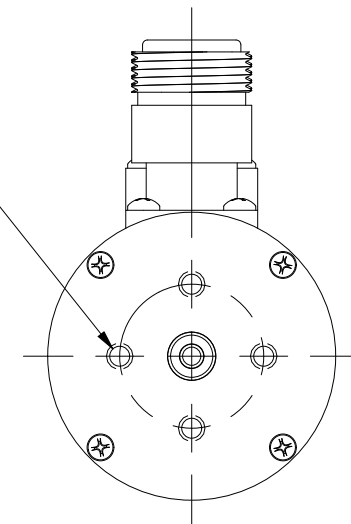

KNOB DETAIL

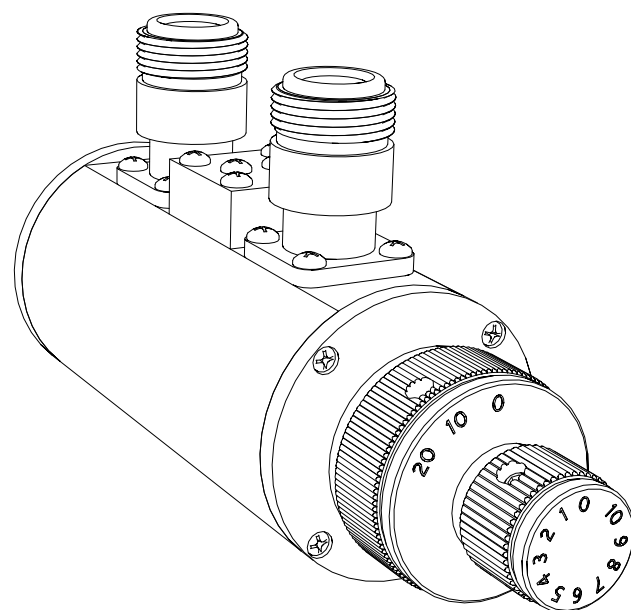

REV	ECN	DATE	BY	APPR
-	ISSUED	9-22-10	TEZ	TEZ
A	24444	9-18-19	GM	TEZ



JFW INDUSTRIES, INC.

www.jfwindustries.com

PH: 317-887-1340

MATERIAL	ALUMINUM ALLOY	PROPRIETARY INFORMATION
FINISH	CHEMFILM TCP	ALL SURFACES ARE TO BE FREE OF BURRS, PITS & SCRATCHES
MODEL	50DR-XXX	TOLERANCES
DESCRIPTION	ROTARY ATTENUATOR	.XX±.010 .XXX±.005 XX°±.5°
		DWG #
		092-6720

SCALE FULL

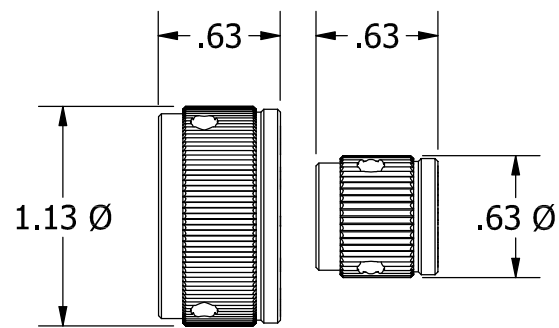
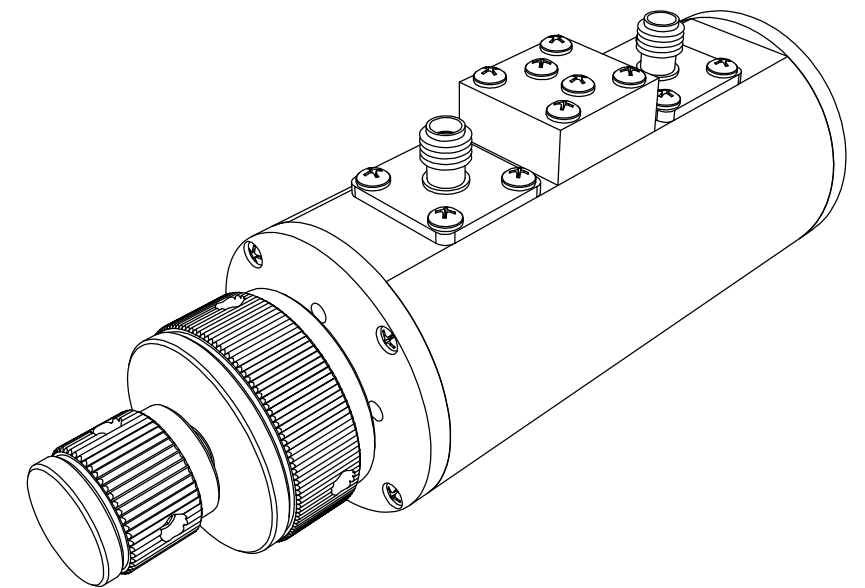
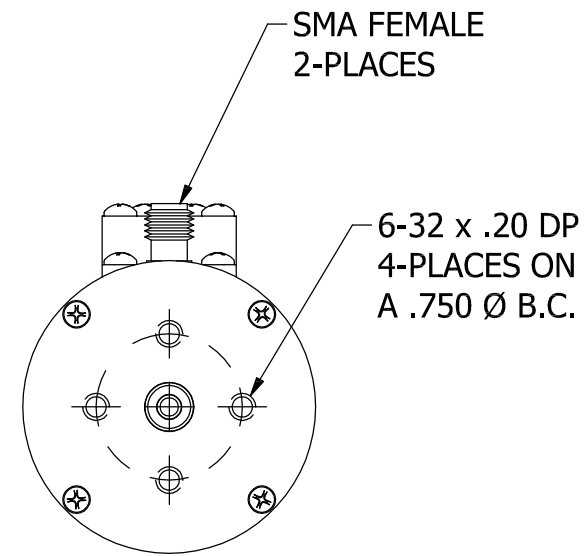
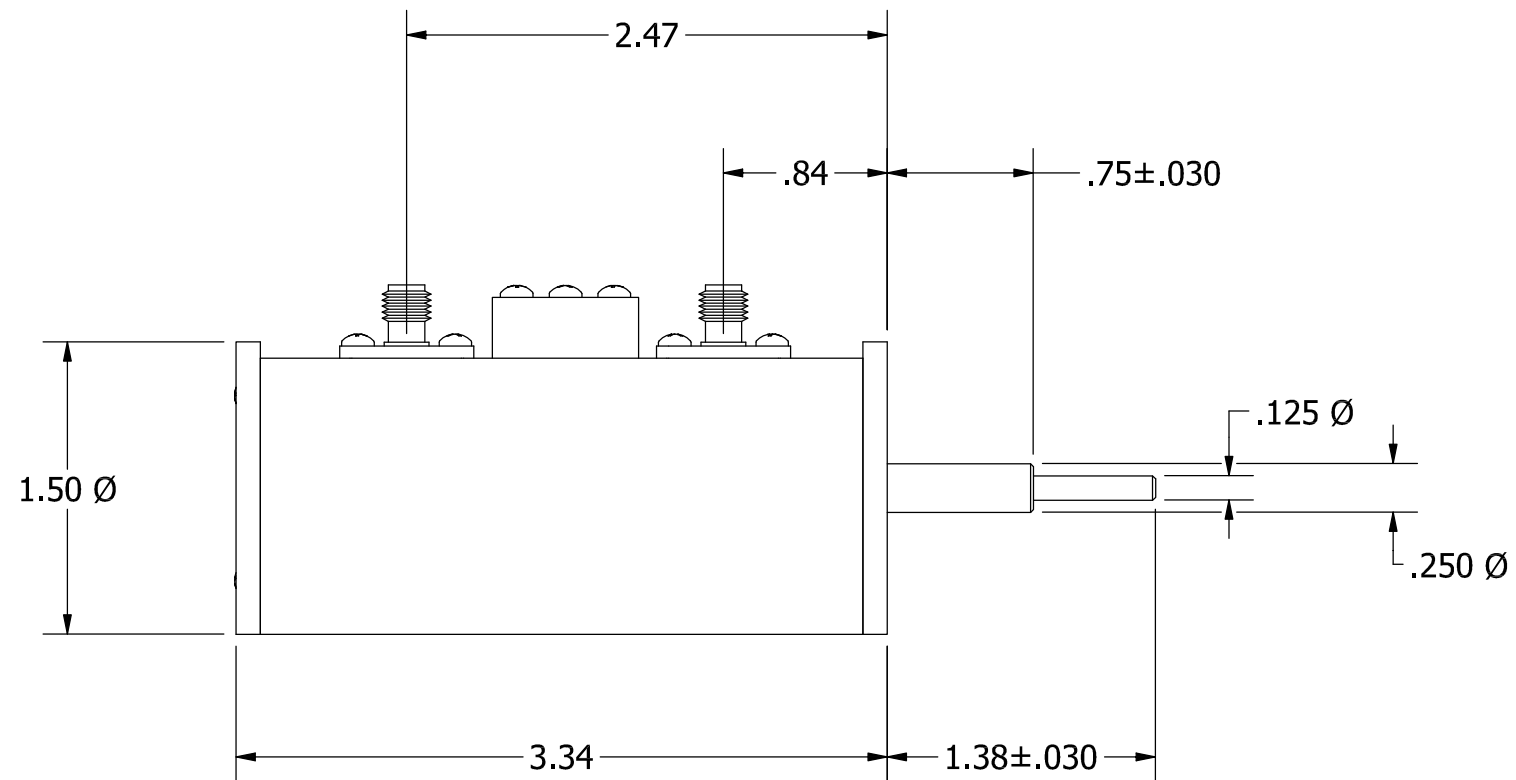

KNOB DETAIL

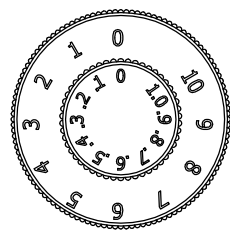

0-11 x 0.1 MODELS

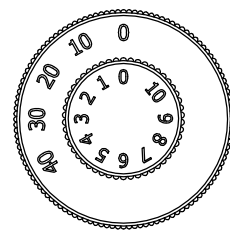

0-50 x 1 MODELS

REV	ECN	DATE	BY	APPR
-	ISSUED	11-2-92	TEZ	FDW
A	3934	4-15-93	TEZ	FDW
B	6166	1-19-00	TEZ	FDW
C	6594	1-24-01	CDJ	TEZ
D	6750	6-11-01	CDJ	TEZ
E	12635	4-20-06	ETW	TEZ
F	23329	10-3-13	JZ	TEZ
G	24444	11-24-15	JZ	TEZ



JFW INDUSTRIES, INC.

www.jfwindustries.com

PH: 317-887-1340

MATERIAL	ALUMINUM ALLOY	PROPRIETARY INFORMATION
FINISH	CHEMFILM TCP	ALL SURFACES ARE TO BE FREE OF BURRS, PITS & SCRATCHES
MODEL	50DR-XXX	SCALE FULL
DESCRIPTION	ROTARY ATTENUATOR	TOLERANCES .XX±.010 .XXX±.005 XX°±.5°
		DWG # 092-1919

