

**SPECIFICATION SHEET**

**JFW MODEL 50DR-111**

**DUAL ROTARY ATTENUATOR**

JFW Industries, Inc.  
Phone: 317-887-1340  
sales@jfwindustries.com  
www.jfwindustries.com

Frequency Range DC-2700 MHz

Impedance 50 Ohms nominal

Attenuation Range 0-60 dB in 1 dB steps

VSWR 1.35:1 maximum DC-1000 MHz  
1.5:1 maximum 1000-2700 MHz

Insertion Loss 0.6 dB maximum DC-1000 MHz  
1.2 dB maximum 1000-2700 MHz

Attenuation Accuracy ± 0.5 dB or 3%  
(whichever is greater)

RF Input Power 2 Watts average  
1000 Watts peak

Direction of Rotation Attenuation increases in a Clockwise  
direction

Indexing 30 degrees with stops at  
Minimum and maximum

RF Connector BNC, N or SMA female

Operating Temperature Range -20°C to +85°C

Lifetime 500,000 attenuation steps (each knob)

Knob/Panel Mounting Drawing 092-8435-02

Outline Drawings 092-1513-05 (50DR-111 BNC)  
092-327-05 (50DR-111 N)  
092-440-05 (50DR-111 SMA)

ECR/ECN #	DATE	REV	APPR / DATE	ECR/ECN #	DATE	REV	APPR / DATE
	11/17/2004		BAC 11/17/2004	28157	10/05/2017	C	TRS 10/05/2017
17283	06/04/2009	A	TRS 06/04/2009	31619	02/18/2022	D	TRS 02/18/2022
25776	09/28/2015	B	TRS 09/29/2015				

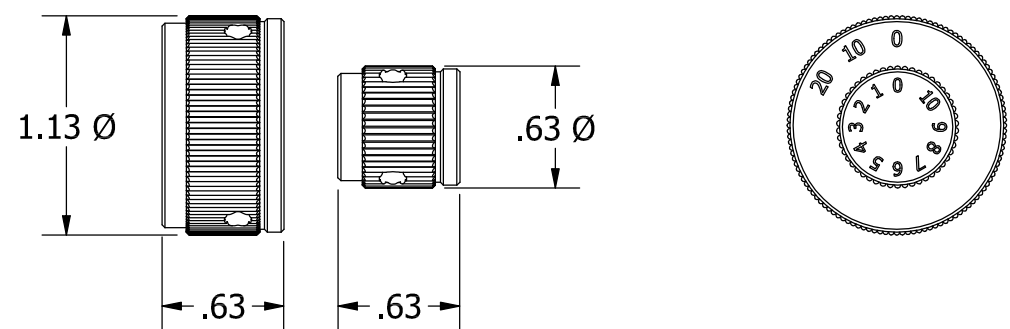
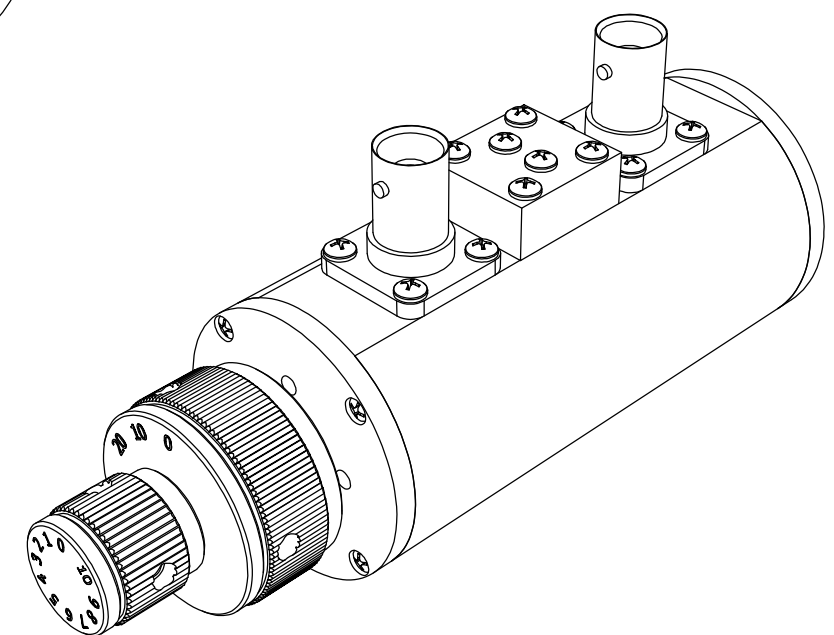
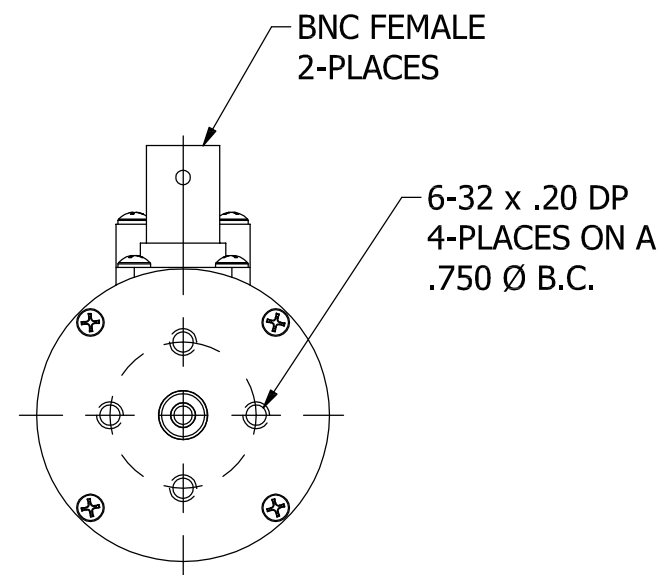
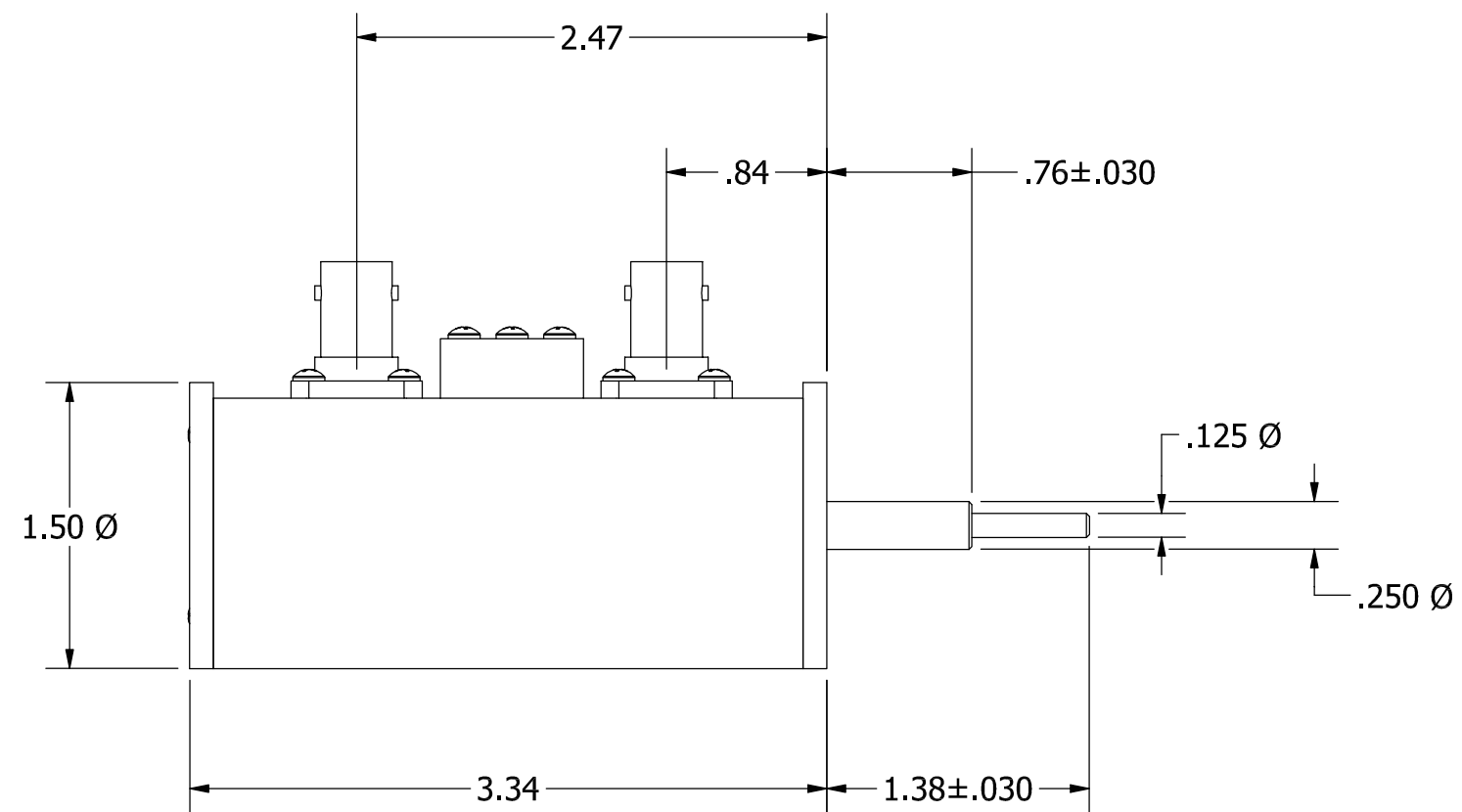

**KNOB DETAIL**

REV	ECN	DATE	BY	APPR
-	ISSUED	4-9-08	TEZ	TRS
A	24444	9-17-15	JZ	TEZ

		<b>JFW INDUSTRIES, INC.</b> <a href="http://www.jfwindustries.com">www.jfwindustries.com</a> PH: 317-887-1340	
		MATERIAL	ALUMINUM ALLOY
FINISH	CHEMFILM TCP	ALL SURFACES ARE TO BE FREE OF BURRS, PITS & SCRATCHES	
MODEL	50DR-XXX	SCALE	FULL
DESCRIPTION	0-30dB ROTARY ATTEN.		TOLERANCES .XX±.010 .XXX±.005 XX°±.5°
			DWG #
			092-5760

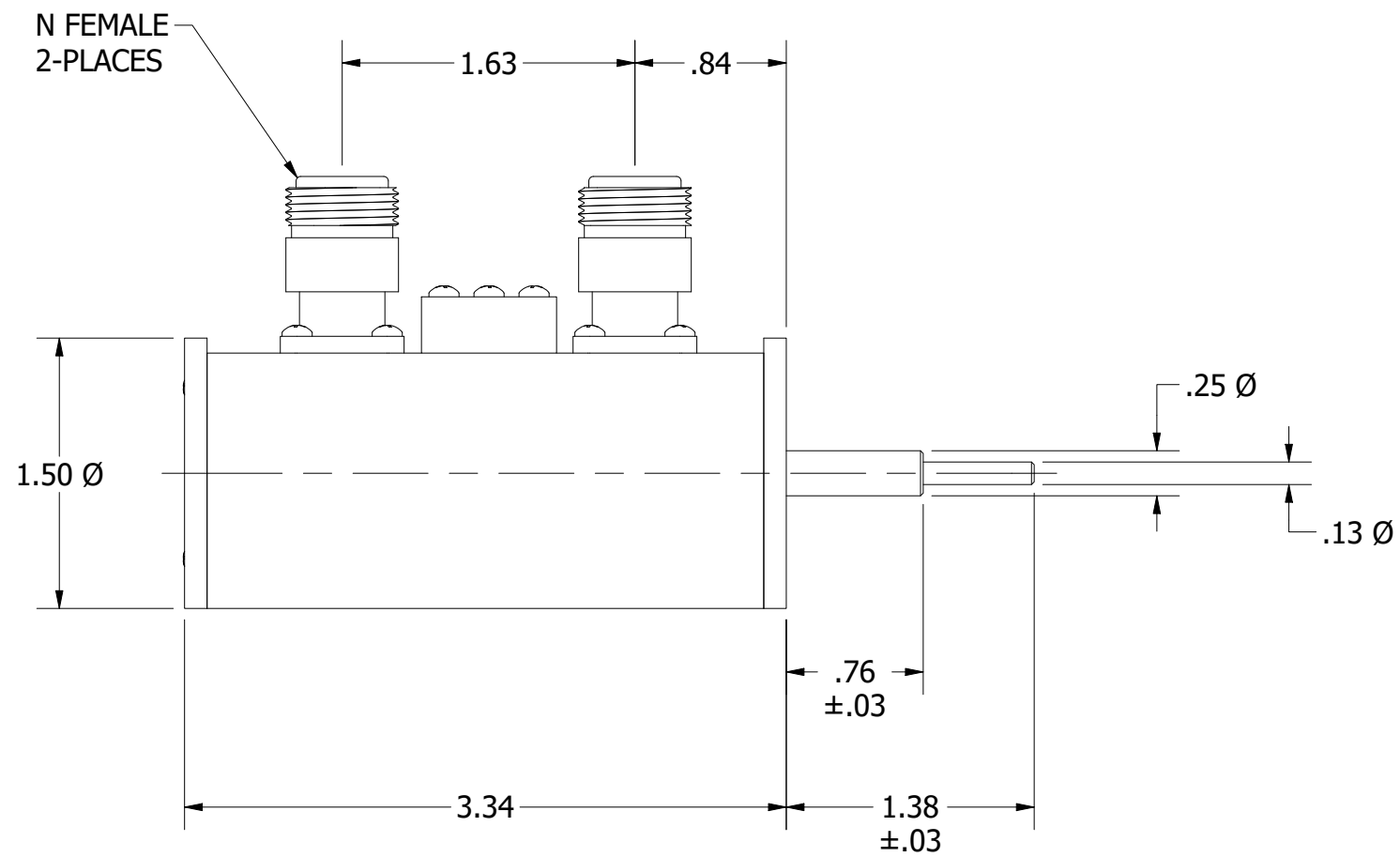

6-32 x .20 DP  
4-PLACES ON  
A .750 Ø B.C.

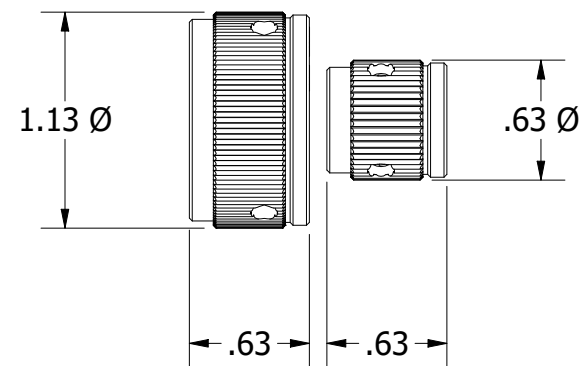
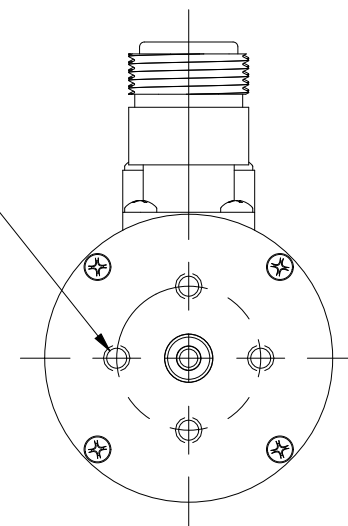

**KNOB DETAIL**

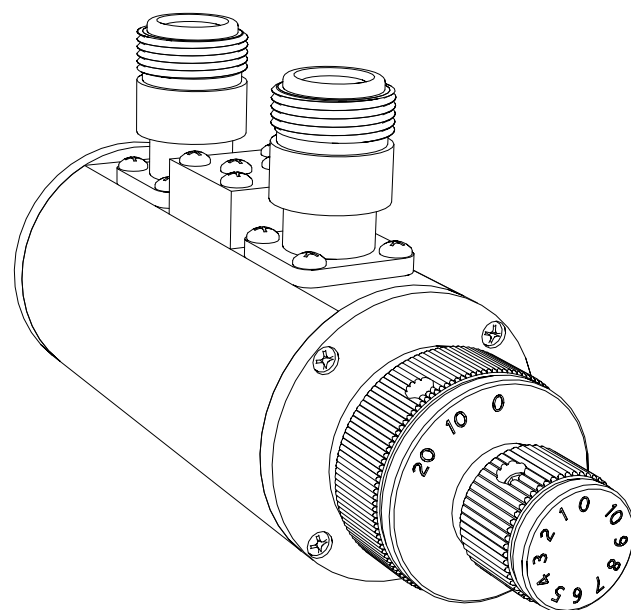

REV	ECN	DATE	BY	APPR
-	ISSUED	9-22-10	TEZ	TEZ
A	24444	9-18-19	GM	TEZ



**JFW INDUSTRIES, INC.**

www.jfwindustries.com

PH: 317-887-1340

MATERIAL	ALUMINUM ALLOY	PROPRIETARY INFORMATION
FINISH	CHEMFILM TCP	ALL SURFACES ARE TO BE FREE OF BURRS, PITS & SCRATCHES
MODEL	50DR-XXX	TOLERANCES
DESCRIPTION	ROTARY ATTENUATOR	.XX±.010 .XXX±.005 XX°±.5°
		DWG #
		092-6720

SCALE FULL

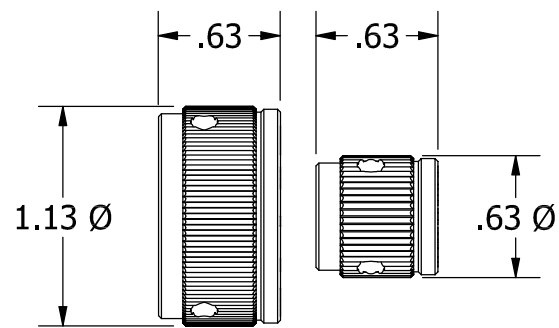
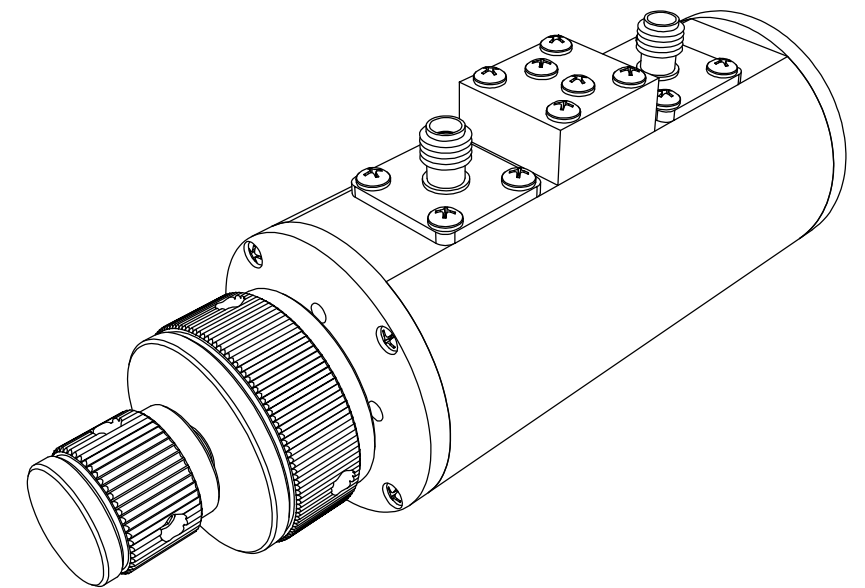
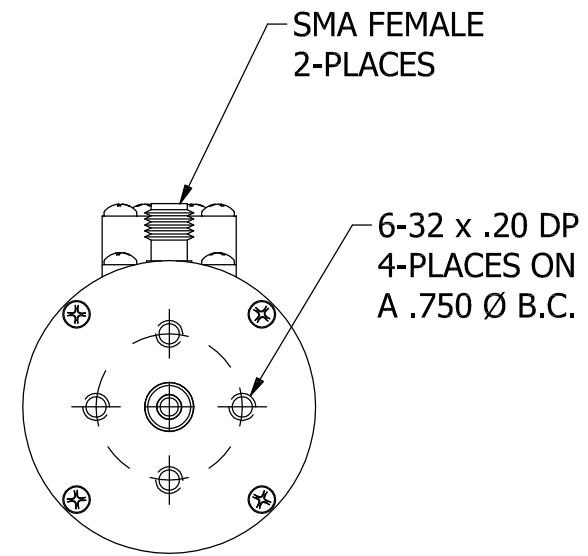
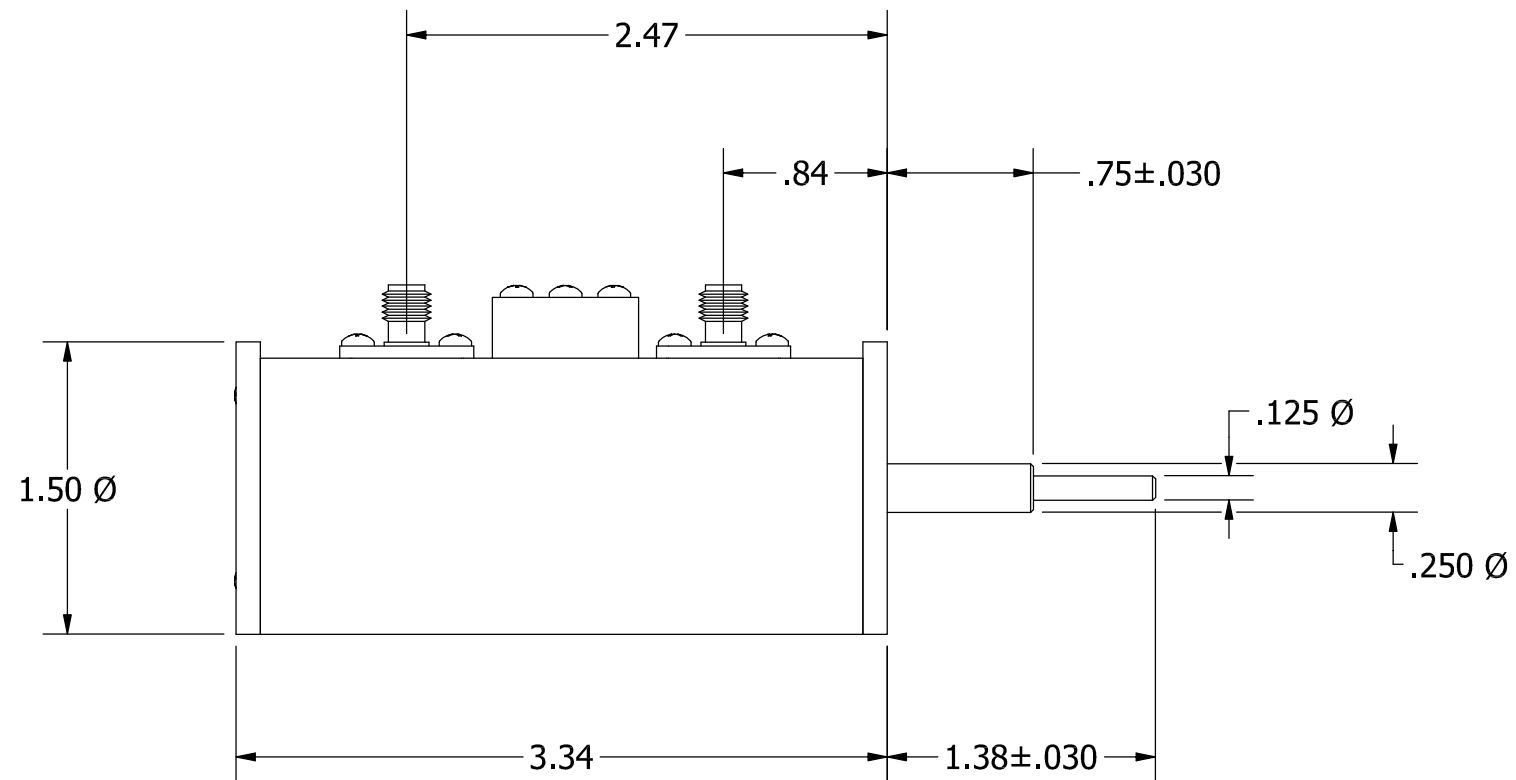

KNOB DETAIL

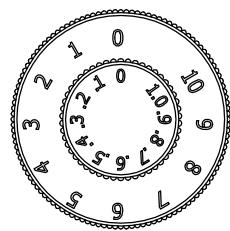

0-11 x 0.1 MODELS

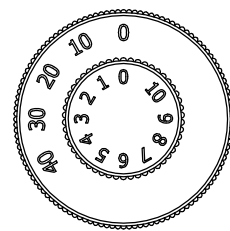

0-50 x 1 MODELS

REV	ECN	DATE	BY	APPR		
-	ISSUED	11-2-92	TEZ	FDW		
A	3934	4-15-93	TEZ	FDW		
B	6166	1-19-00	TEZ	FDW		
C	6594	1-24-01	CDJ	TEZ		
D	6750	6-11-01	CDJ	TEZ		
E	12635	4-20-06	ETW	TEZ		
F	23329	10-3-13	JZ	TEZ		
G	24444	11-24-15	JZ	TEZ		
					<b>JFW INDUSTRIES, INC.</b>	
					<i>www.jfwindustries.com</i> PH: 317-887-1340	
					MATERIAL	ALUMINUM ALLOY
					FINISH	CHEMFILM TCP
					MODEL	50DR-XXX
					SCALE	FULL
					DESCRIPTION	ROTARY ATTENUATOR
					PROPRIETARY INFORMATION ALL SURFACES ARE TO BE FREE OF BURRS, PITS & SCRATCHES TOLERANCES .XX±.010 .XXX±.005 XX°±.5° DWG #	
					092-1919	

