

SPECIFICATION SHEET

JFW MODEL 50R-043

ROTARY ATTENUATOR

JFW Industries, Inc.
Phone: 317-887-1340
sales@jfwindustries.com
www.jfwindustries.com

Frequency Range DC-1000 MHz

Impedance 50 Ohms nominal

Attenuation Range 0-100 dB in 10 dB steps

VSWR 1.2:1 maximum

Insertion Loss 0.3 dB maximum

Attenuation Accuracy ± 0.5 dB or 2%
(whichever is greater)

RF Input Power 2 Watts average
1000 Watts peak

Direction of Rotation Attenuation increases in a Clockwise
direction

Indexing 30 degrees with stops at
Minimum and maximum

RF Connector BNC, N, SMA, or TNC

Operating Temperature Range -20°C to +85°C

Lifetime 500,000 attenuation steps

Knob/Panel Mounting Drawing 092-8435-01

Outline Drawing Numbers 092-9530-01 (50R-043 SMA)
092-9530-02 (50R-043 BNC)
092-9530-03 (50R-043 N)
092-428-02 (50R-043 BNC/SMA)
092-428-04 (50R-043 N/SMA)
092-428-05 (50R-043 TNC)
092-428-06 (50R-043 TNC/SMA)
092-428-08 (50R-043 N F/M)
092-428-09 (50R-043 N M/F)

ECR/ECN #	DATE	REV	APPR / DATE	ECR/ECN #	DATE	REV	APPR / DATE
17378	07/02/2009	C	TRS 07/02/2009	25776	09/28/2015	F	TRS 09/29/2015
18358	03/05/2010	D	TRS 03/05/2010	28157	10/05/2017	G	TRS 10/05/2017
19092	09/03/2010	E	TRS 09/03/2010	30381	05/11/2020	H	TRS 05/11/2020

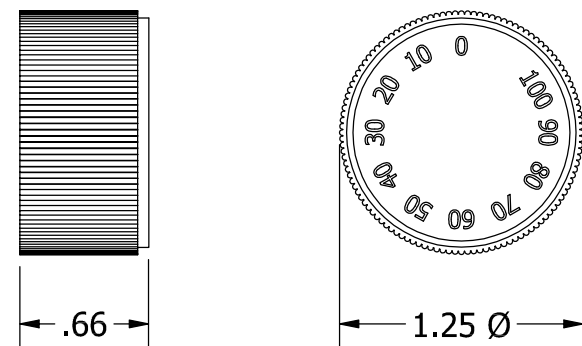
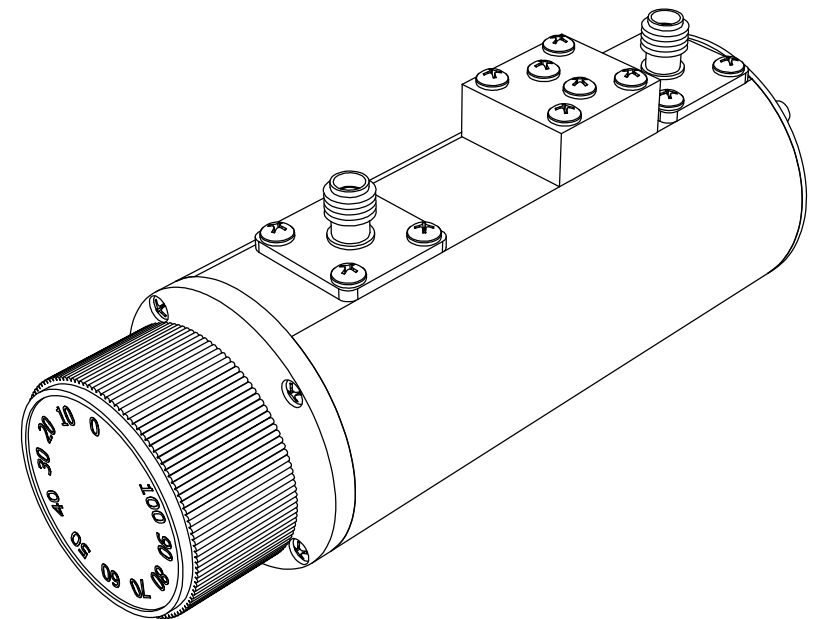
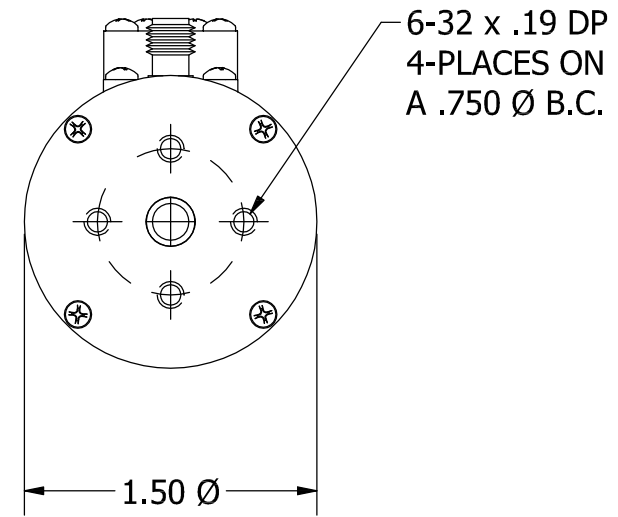
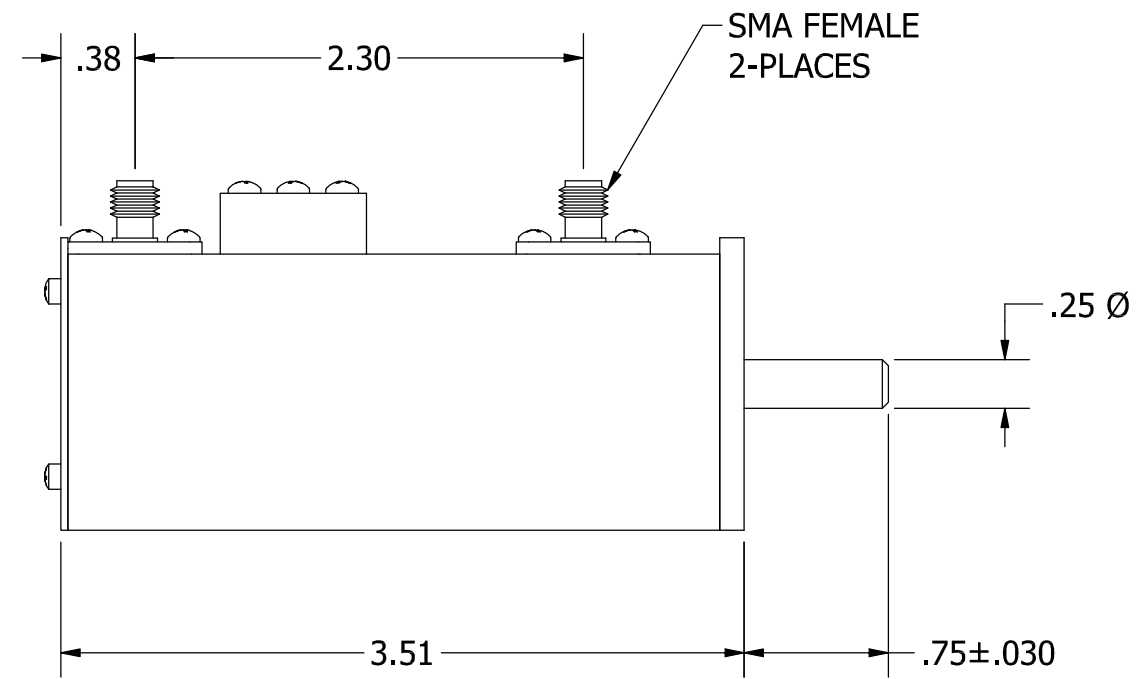

KNOB DETAIL

REV	ECN	DATE	BY	APPR
-	ISSUED	2-10-95	CDJ	FDW
A	4581	3-1-95	TEZ	FDW
B	4983	5-21-96	TEZ	FDW
C	6532	12-11-00	CDJ	TEZ
D	6750	6-11-01	CDJ	TEZ
E	12635	4-20-06	ETW	TEZ
F	24444	9-11-15	JZ	TEZ



JFW INDUSTRIES, INC.

www.jfwindustries.com

PH: 317-887-1340

MATERIAL	ALUMINUM ALLOY	PROPRIETARY INFORMATION
FINISH	CHEMFILM TCP	ALL SURFACES ARE TO BE FREE OF BURRS, PITS & SCRATCHES
MODEL	50R-XXX	SCALE FULL TOLERANCES .XX±.010 .XXX±.005 XX°±.5°
DESCRIPTION	0-100 dB ROTARY ATTEN.	DWG # 092-2275

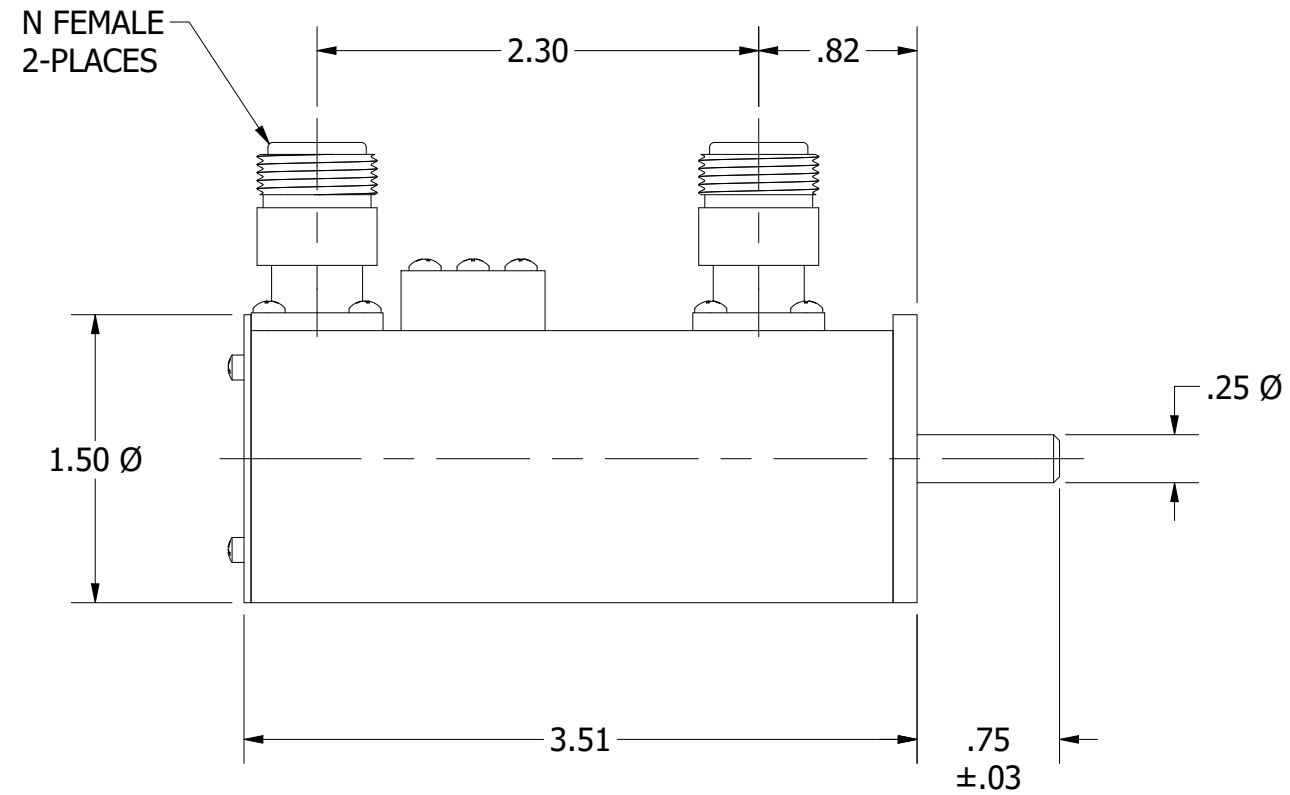

6-32 x .19 DP
4-PLACES ON
A .750 Ø B.C.

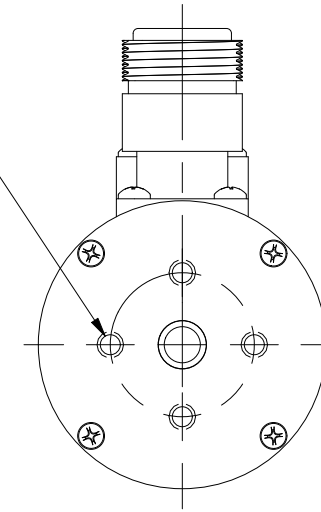

KNOB MARKED PER UNIT
0-100 dB x 10 dB SHOWN

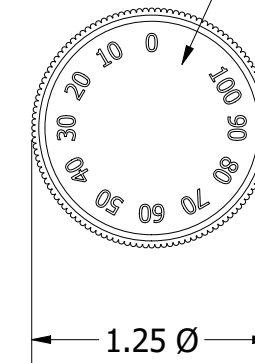
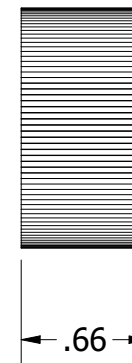

KNOB DETAIL

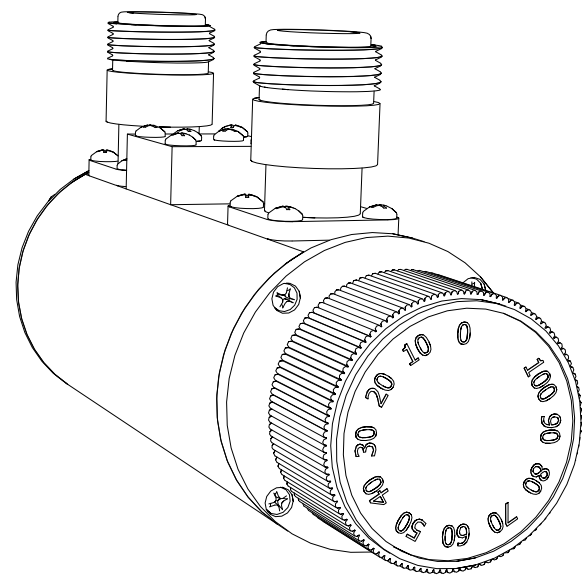

REV	ECN	DATE	BY	APPR
-	ISSUED	6-10-09	BZ	TRS
A	24444	9-17-19	GM	TEZ



JFW INDUSTRIES, INC.

www.jfwindustries.com

PH: 317-887-1340

MATERIAL	ALUMINUM ALLOY	PROPRIETARY INFORMATION
FINISH	CHEMFILM TCP	ALL SURFACES ARE TO BE FREE OF BURRS, PITS & SCRATCHES
MODEL	50R-XXX	TOLERANCES .XX±.010 .XXX±.005 XX°±.5°
DESCRIPTION	ROTARY ATTENUATOR	DWG # 092-6200-03

