

SPECIFICATION SHEET

JFW MODEL 50R-215

ROTARY ATTENUATOR

JFW Industries, Inc.
Phone: 317-887-1340
sales@jfwindustries.com
www.jfwindustries.com

Frequency Range DC-2200 MHz

Impedance 50 Ohms nominal

Attenuation Range 0-1 dB in 0.1 dB steps

VSWR 1.2:1 maximum DC-1000 MHz
1.4:1 maximum 1000-2200 MHz

Insertion Loss 1 dB maximum

Attenuation Accuracy ± 0.05 dB

RF Input Power 2 Watts average

Direction of Rotation Attenuation increases in a Clockwise direction

Indexing 30 degrees with stops at Minimum and maximum

RF Connector BNC, SMA or TNC female

Operating Temperature Range -20°C to +85°C

Lifetime 500,000 attenuation steps

Knob/Panel Mounting Drawing 092-8435-01

Outline Drawings 092-9529-01 (50R-215 SMA)
092-9529-02 (50R-215 BNC)
092-9529-03 (50R-215 TNC)

ECR/ECN #	DATE	REV	APPR / DATE	ECR/ECN #	DATE	REV	APPR / DATE
	04/19/1993			25776	09/29/2015	C	TRS 09/29/2015
9999	04/30/2003	A	TRS 05/16/2007	28157	10/05/2017	D	TRS 10/05/2017
20829	11/01/2011	B	TRS 11/01/2011	30382	05/11/2020	E	TRS 05/11/2020

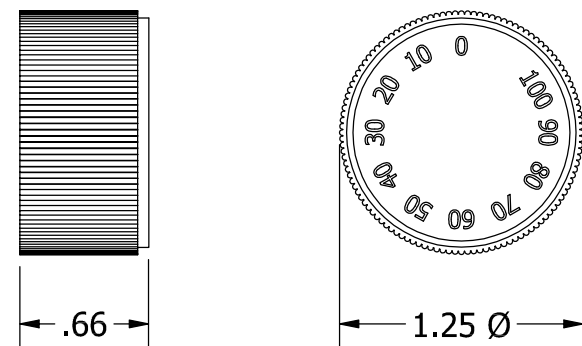
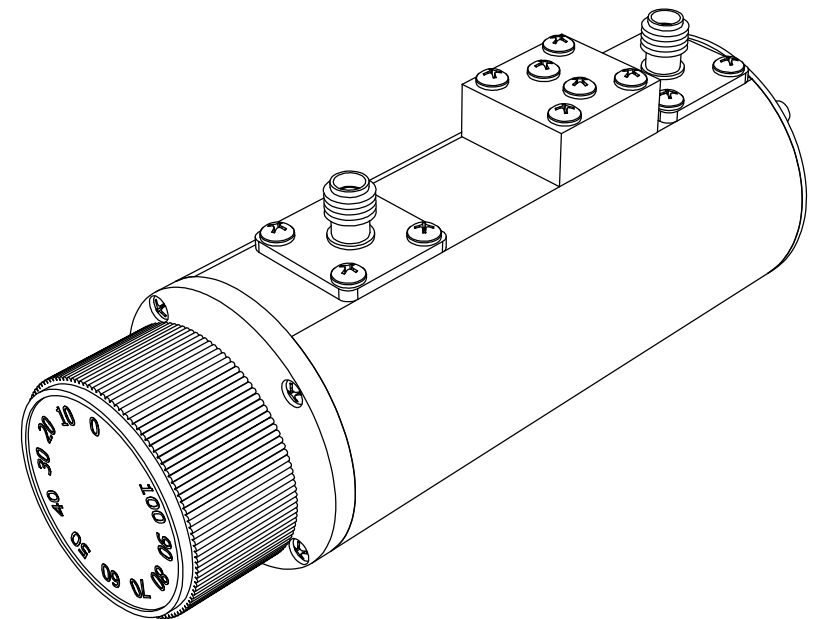
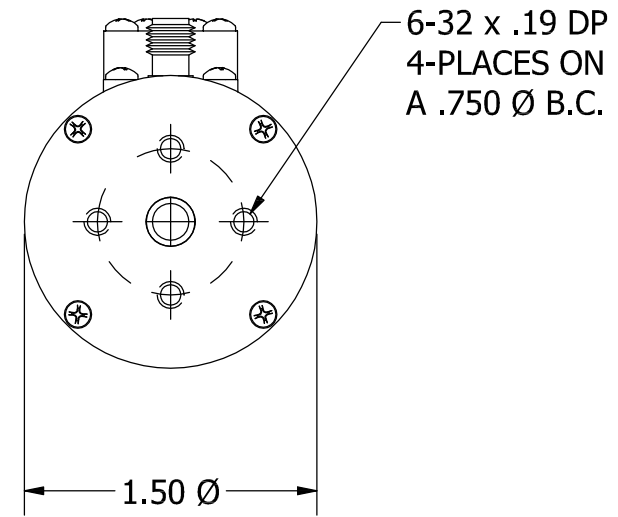
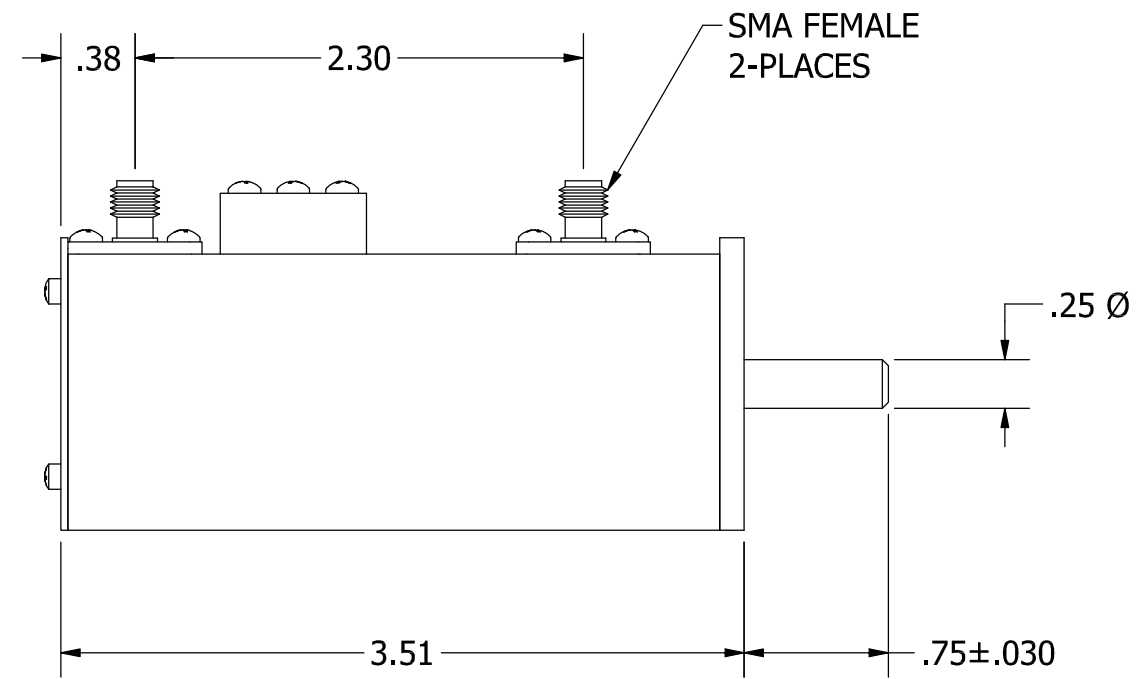

KNOB DETAIL

REV	ECN	DATE	BY	APPR
-	ISSUED	2-10-95	CDJ	FDW
A	4581	3-1-95	TEZ	FDW
B	4983	5-21-96	TEZ	FDW
C	6532	12-11-00	CDJ	TEZ
D	6750	6-11-01	CDJ	TEZ
E	12635	4-20-06	ETW	TEZ
F	24444	9-11-15	JZ	TEZ



JFW INDUSTRIES, INC.

www.jfwindustries.com

PH: 317-887-1340

MATERIAL	ALUMINUM ALLOY	PROPRIETARY INFORMATION
FINISH	CHEMFILM TCP	ALL SURFACES ARE TO BE FREE OF BURRS, PITS & SCRATCHES
MODEL	50R-XXX	TOLERANCES .XX±.010 .XXX±.005 XX°±.5°
DESCRIPTION	0-100 dB ROTARY ATTEN.	DWG # 092-2275

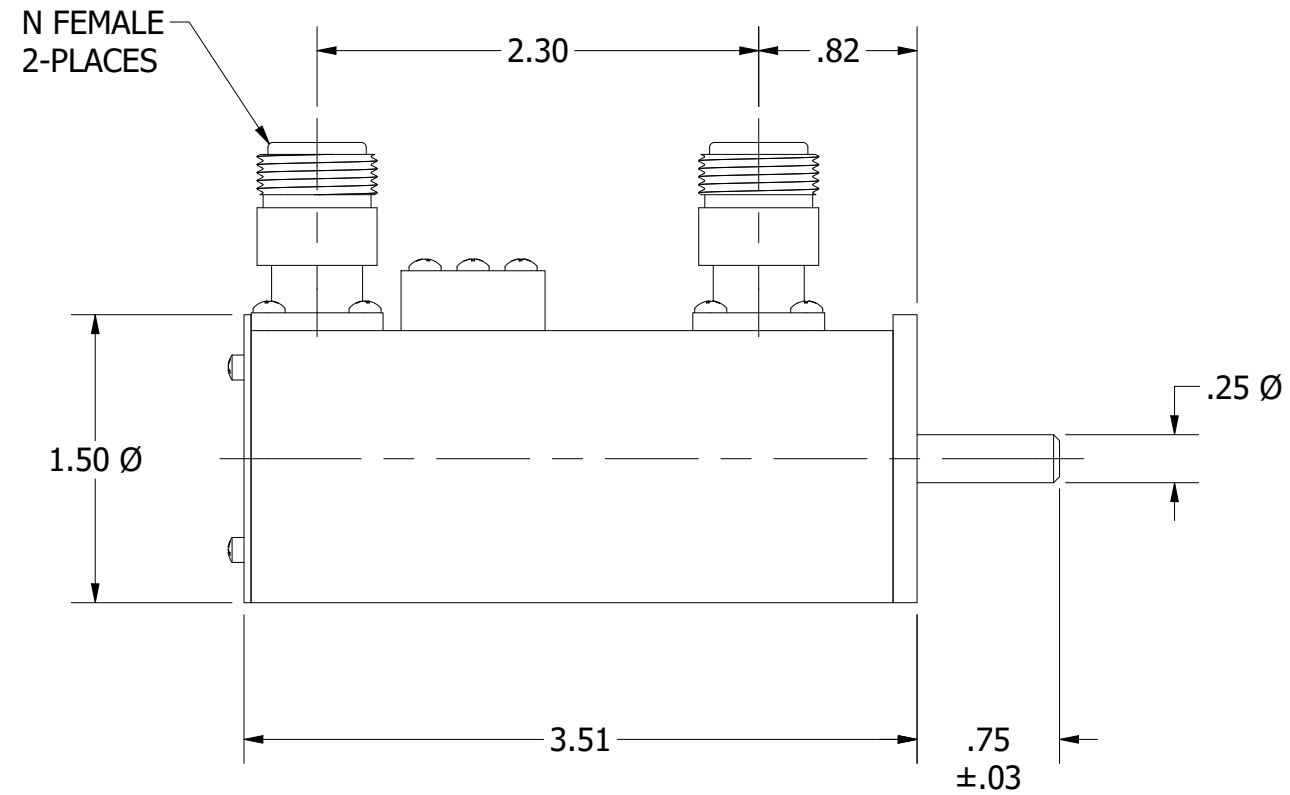

6-32 x .19 DP
4-PLACES ON
A .750 Ø B.C.

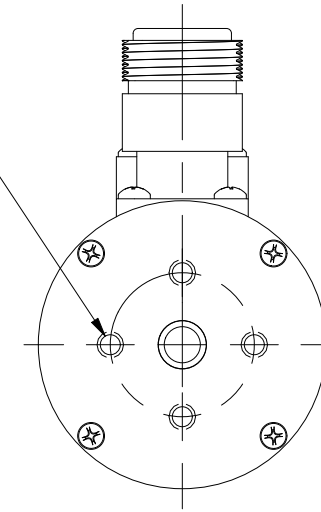

KNOB MARKED PER UNIT
0-100 dB x 10 dB SHOWN

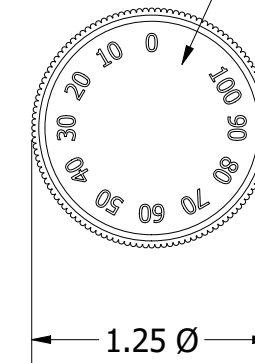
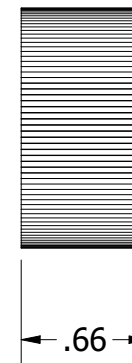

KNOB DETAIL

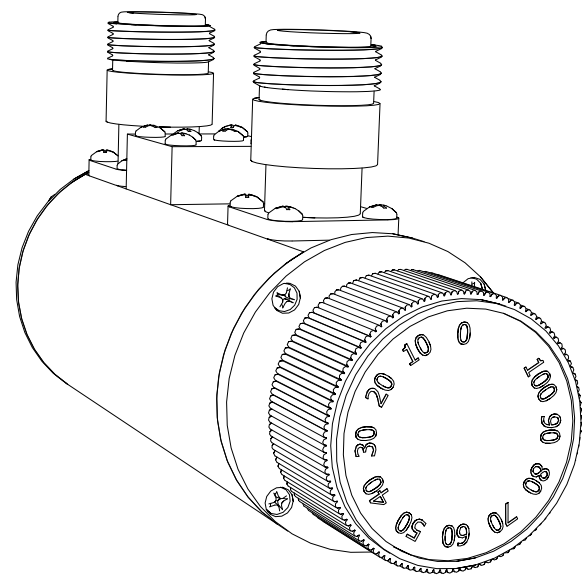

REV	ECN	DATE	BY	APPR
-	ISSUED	6-10-09	BZ	TRS
A	24444	9-17-19	GM	TEZ



JFW INDUSTRIES, INC.

www.jfwindustries.com

PH: 317-887-1340

MATERIAL	ALUMINUM ALLOY	PROPRIETARY INFORMATION
FINISH	CHEMFILM TCP	ALL SURFACES ARE TO BE FREE OF BURRS, PITS & SCRATCHES
MODEL	50R-XXX	TOLERANCES
DESCRIPTION	ROTARY ATTENUATOR	.XX±.010 .XXX±.005 XX°±.5°
		DWG #
		092-6200-03

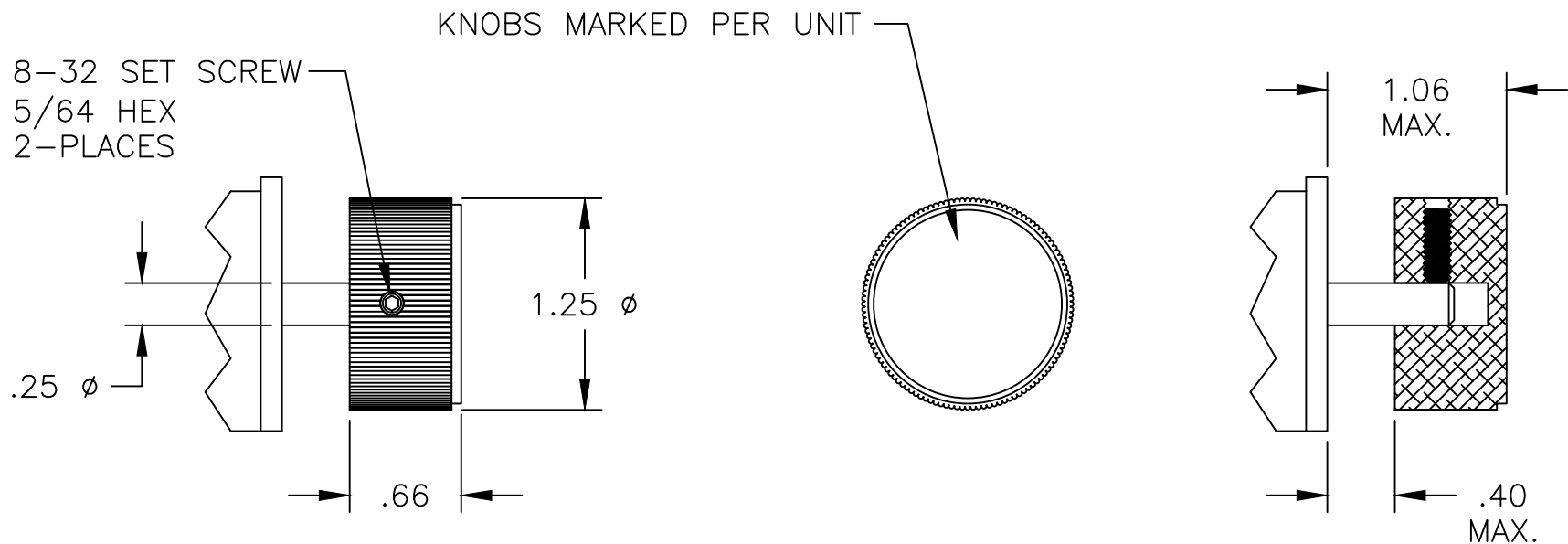

NOTE: PANEL THICKNESS IN ADDITION TO SCREW HEAD MUST NOT EXCEED .40 MAX.

REV	ECN	DATE	BY	APPR	 JFW INDUSTRIES, INC. www.jfwindustries.com PH: 317-887-1340	
-	ISSUED	9-24-15	JZ	TEZ	MATERIAL PLASTIC / ALUMINUM INLAY FINISH BLACK / CLEAR MODEL 132-001 DESCRIPTION ROTOR KNOB MOUNTING	
A	30055	12-10-19	JZ	TEZ		
					SCALE	FULL
					PROPRIETARY INFORMATION ALL SURFACES ARE TO BE FREE OF BURRS, PITS, & SCRATCHES TOLERANCES .XX±.010 .XXX±.005 XX±.5' DWG # 092-8435-01	