

SPECIFICATION SHEET

JFW MODEL 50R-310

ROTARY ATTENUATOR

JFW Industries, Inc.
Phone: 317-887-1340
sales@jfwindustries.com
www.jfwindustries.com

Frequency Range	DC-2700 MHz
Impedance	50 Ohms nominal
Attenuation Range	0-10 dB in 1 dB steps
VSWR	1.2:1 maximum DC-1000 MHz 1.4:1 maximum 1000-2700 MHz
Insertion Loss	0.5 dB maximum 0.11 dB typical @ 1000 MHz 0.23 dB typical @ 2700 MHz
Attenuation Accuracy	± 0.5 dB
RF Input Power	2 Watts average 1000 Watts peak
Direction of Rotation	Attenuation increases in a Clockwise direction
Indexing	30 degrees with stops at Minimum and maximum
RF Connector	SMA female
Operating Temperature Range	-20°C to +85°C
Lifetime	500,000 attenuation steps
Knob/Panel Mounting Drawing	092-8435-01
Outline Drawing	092-039 (50R-310 SMA)

ECR/ECN #	DATE	REV	APPR / DATE	ECR/ECN #	DATE	REV	APPR / DATE
16402	10/15/2008	D	TRS 10/15/2008	25776	09/29/2015	G	TRS 09/29/2015
16574	12/02/2008	E	TRS 12/02/2008	28157	10/05/2017	H	TRS 10/05/2017
20344	07/19/2011	F	TRS 07/19/2011	30227	02/27/2020	I	TRS 02/27/2020

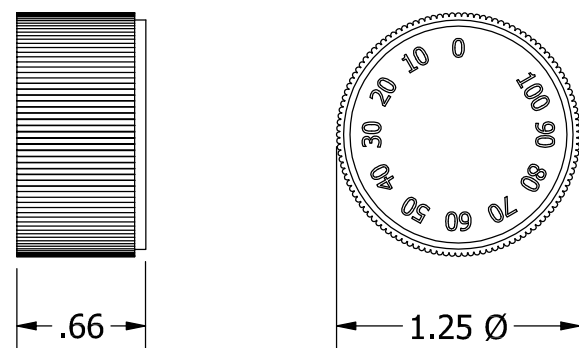
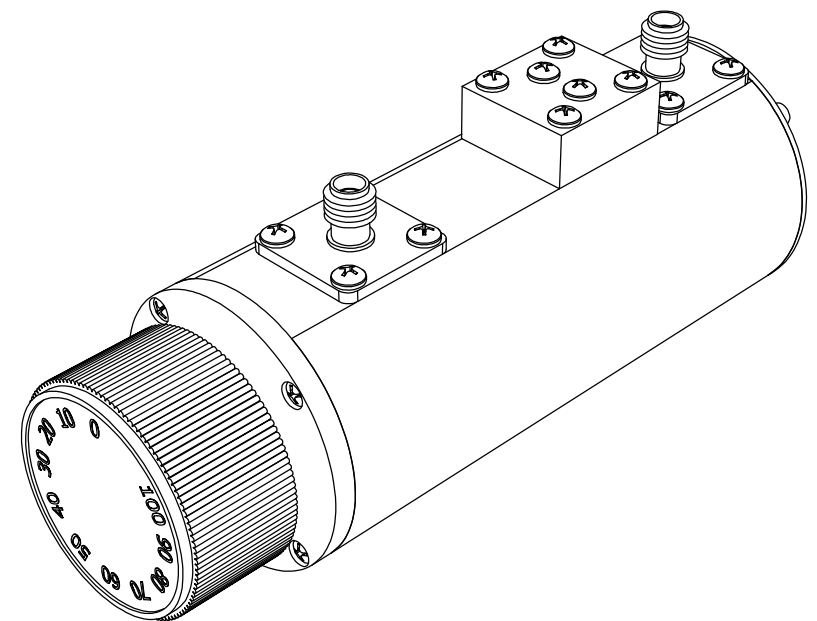
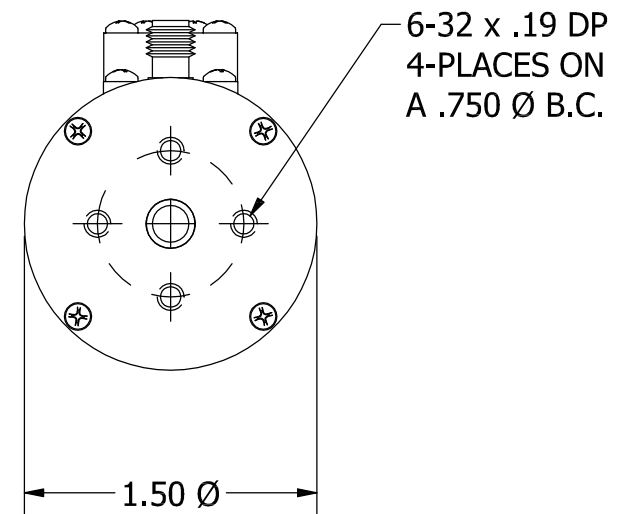
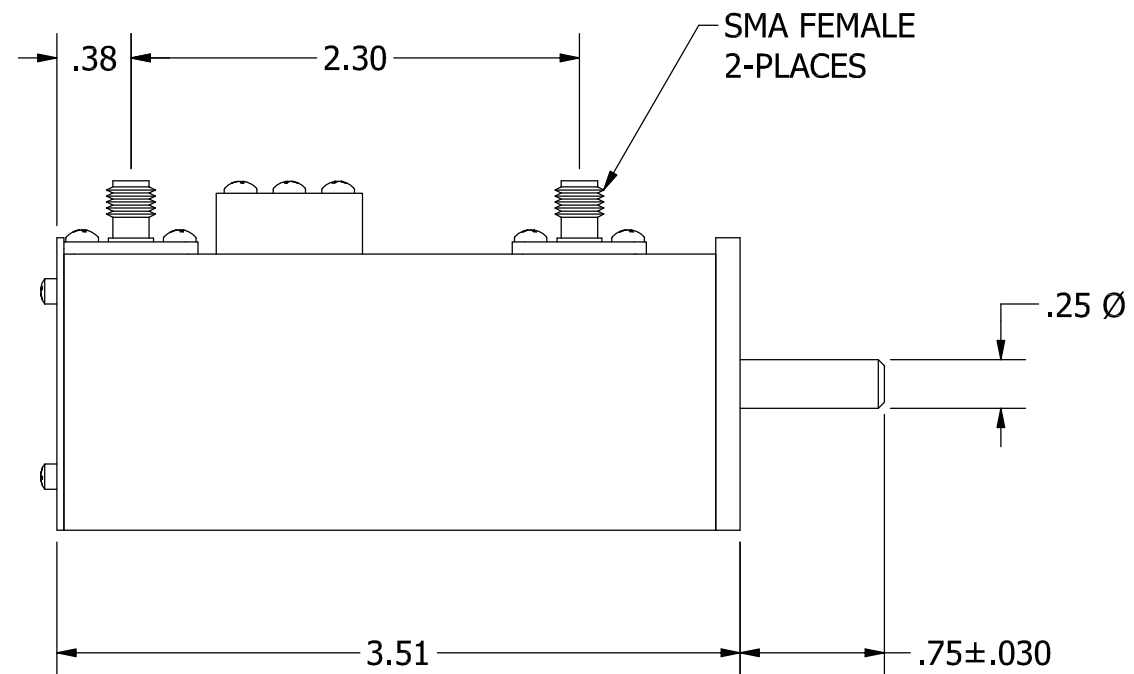

KNOB DETAIL

REV	ECN	DATE	BY	APPR			
-	ISSUED	2-10-95	CDJ	FDW			
A	4581	3-1-95	TEZ	FDW			
B	4983	5-21-96	TEZ	FDW			
C	6532	12-11-00	CDJ	TEZ			
D	6750	6-11-01	CDJ	TEZ			
E	12635	4-20-06	ETW	TEZ			
F	24444	9-11-15	JZ	TEZ			
					 JFW INDUSTRIES, INC. www.jfwindustries.com PH: 317-887-1340		
					MATERIAL	ALUMINUM ALLOY	PROPRIETARY INFORMATION
					FINISH	CHEMFILM TCP	ALL SURFACES ARE TO BE FREE OF BURRS, PITS & SCRATCHES
					MODEL	50R-XXX	SCALE FULL
					DESCRIPTION	0-100 dB ROTARY ATTEN.	TOLERANCES .XX±.010 .XXX±.005 XX°±.5°
							DWG # 092-2275

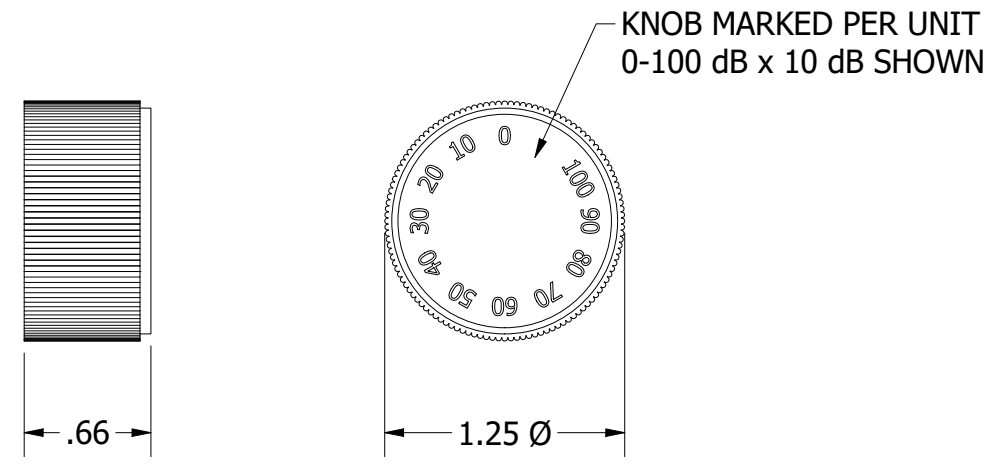
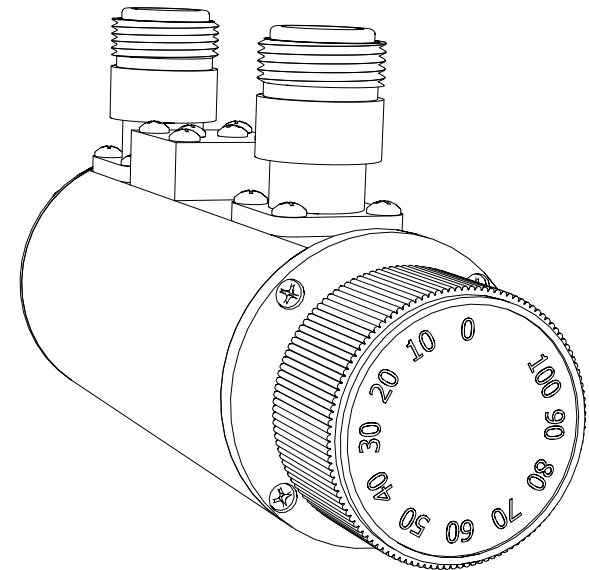
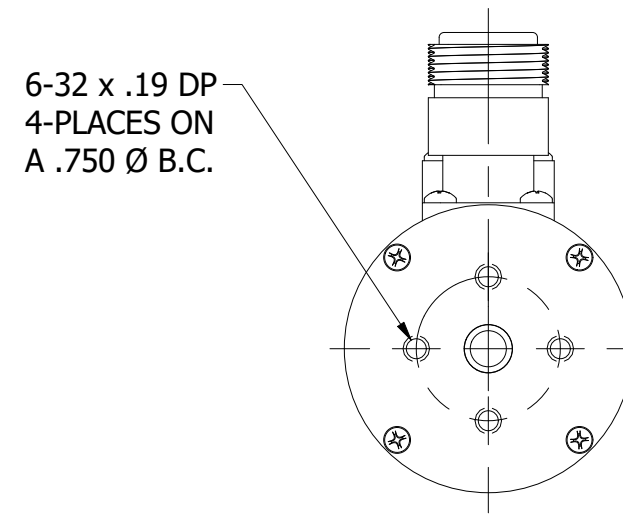
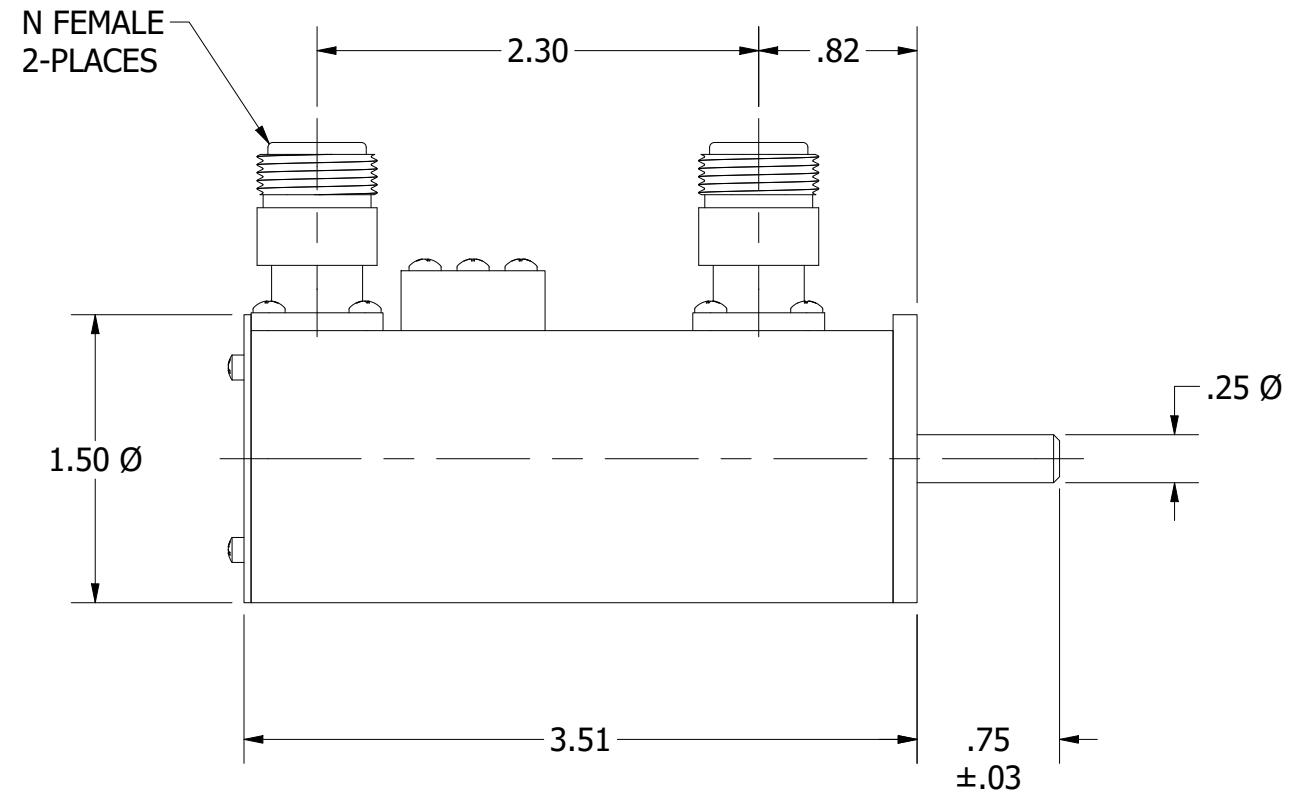

KNOB DETAIL

REV	ECN	DATE	BY	APPR
-	ISSUED	6-10-09	BZ	TRS
A	24444	9-17-19	GM	TEZ

		JFW INDUSTRIES, INC. www.jfwindustries.com PH: 317-887-1340	
FINISH		CHEMFILM TCP	ALL SURFACES ARE TO BE FREE OF BURRS, PITS & SCRATCHES
MODEL		50R-XXX	TOLERANCES .XX±.010 .XXX±.005 XX°±.5°
DESCRIPTION		ROTARY ATTENUATOR	DWG # 092-6200-03
SCALE		FULL	

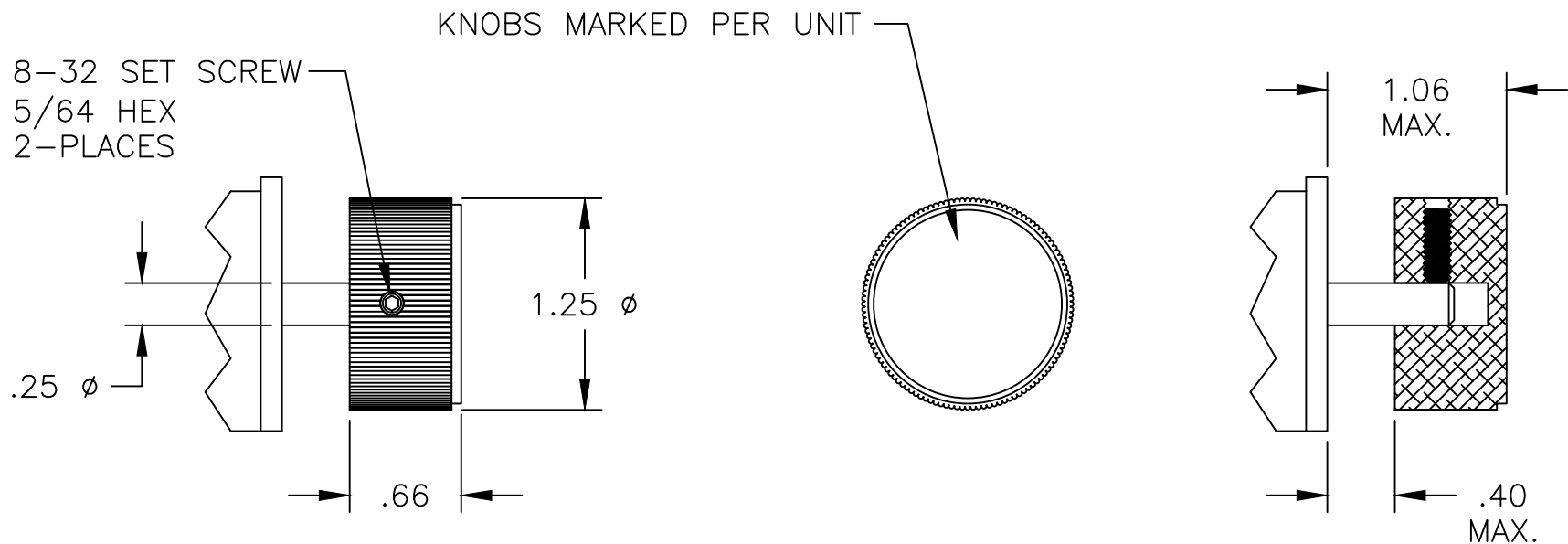

NOTE: PANEL THICKNESS IN ADDITION TO SCREW HEAD MUST NOT EXCEED .40 MAX.

REV	ECN	DATE	BY	APPR	 JFW INDUSTRIES, INC. www.jfwindustries.com PH: 317-887-1340	
-	ISSUED	9-24-15	JZ	TEZ	MATERIAL PLASTIC / ALUMINUM INLAY FINISH BLACK / CLEAR MODEL 132-001 DESCRIPTION ROTOR KNOB MOUNTING	
A	30055	12-10-19	JZ	TEZ		
					SCALE	FULL
					PROPRIETARY INFORMATION ALL SURFACES ARE TO BE FREE OF BURRS, PITS, & SCRATCHES TOLERANCES .XX±.010 .XXX±.005 XX±.5' DWG # 092-8435-01	