

SPECIFICATION SHEET
JFW MODEL 50T-439-XXX
TERMINATION/MISMATCH

JFW Industries, Inc.
 Phone: 317-887-1340
 sales@jfwindustries.com
 www.jfwindustries.com

Frequency Range DC-3000 MHz

Impedance 50 Ohms (referenced)

Available VSWR Values 1.0:1 thru 5.0:1 in any 0.1 increment
 (1.0:1 = termination)

VSWR Tolerance (Termination) 1.15:1 maximum (50T-439-1.0)

VSWR Tolerance (Mismatches) ± 10% from mismatch value

RF Input Power 10 Watts average @ +25°C
 Derate to 5 Watts @ +70°C

Peak Power 1000 Watts (1 microsecond pulse)

RF Connector N, TNC, BNC, SMA or 7/16
 (male or female)

Optional Bead Chain Add a "-BC" to the model number to add the bead chain
 option (See example models below)

Operating Temperature Range -55°C to +100°C

Outline Drawing Numbers 092-9861 (BNC male)
 092-5316 (BNC female)
 092-4885 (N male)
 092-7438 (N male with Bead Chain)
 092-8491 (SMA male)
 092-6409 (TNC male)
 092-7334 (7/16 male)

XXX - Insert VSWR value required.
 Other values available upon request.

Example Model Numbers:

50T-439-1.0 N M Termination (1.0:1) with N male
 50T-439-1.5 SMA M 1.5:1 mismatch with SMA male
 50T-439-5.0 7/16 M 5.0:1 mismatch with 7/16 male
 50T-439-BC-1.5 N M 1.5:1 mismatch with N male and Bead Chain
 50T-439-BC-2.0 N M 2.0:1 mismatch with N male and Bead Chain

| ECR/ECN # | DATE | REV | APPR / DATE | ECR/ECN # | DATE | REV | APPR / DATE |
|-----------|------------|-----|----------------|-----------|------------|-----|----------------|
| 18018 | 12/17/2009 | A | SMR 12/17/2009 | 23288 | 09/30/2013 | D | TRS 09/30/2013 |
| 21478 | 04/23/2012 | B | TRS 04/23/2012 | 25966 | 11/25/2015 | E | BAC 11/25/2015 |
| 21836 | 08/21/2012 | C | TRS 08/21/2012 | 31705 | 04/07/2022 | F | TRS 04/07/2022 |

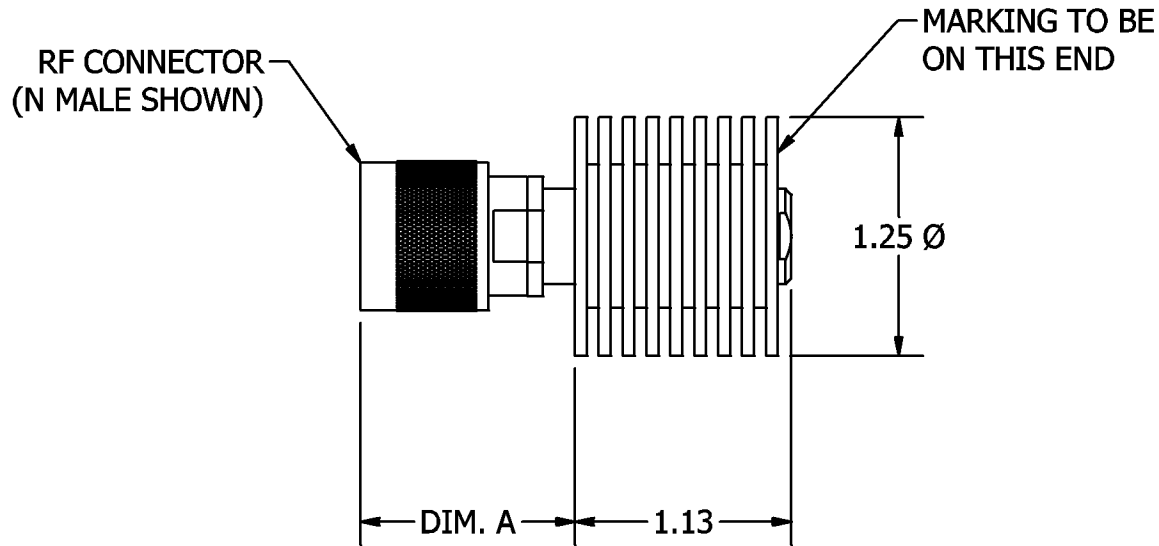

| CONNECTOR | DIM. A ±.03 |
|----------------|-------------|
| SMA MALE | .73 |
| SMA FEMALE | .69 |
| BNC MALE | .97 |
| BNC FEMALE | .77 |
| TNC MALE | .97 |
| TNC FEMALE | .77 |
| N MALE | 1.12 |
| N FEMALE | .89 |
| 4.1/9.5 MALE | 1.12 |
| 4.1/9.5 FEMALE | 1.12 |
| 4.3/10 MALE | 1.23 |
| 4.3/10 FEMALE | 1.19 |

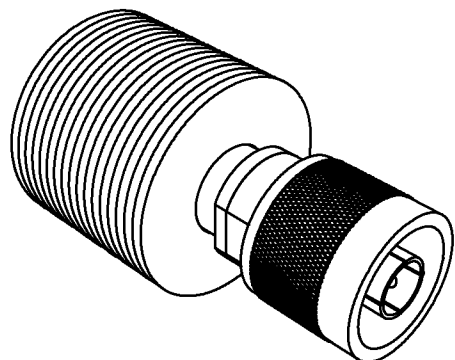

| REV | ECN | DATE | BY | APPR |
|-----|--------|---------|-----|------|
| - | ISSUED | 7-27-05 | TEZ | SL |
| A | 26593 | 4-29-16 | TEZ | TRS |
| B | 266684 | 5-26-16 | TEZ | TEZ |
| C | 24444 | 9-13-19 | GM | JZ |



JFW INDUSTRIES, INC.

www.jfwindustries.com

PH: 317-887-1340

| | | |
|-------------|---------------------|--|
| MATERIAL | ALUMINUM ALLOY | PROPRIETARY INFORMATION |
| FINISH | BLACK ANODIZE | ALL SURFACES ARE TO BE FREE OF BURRS, PITS & SCRATCHES |
| MODEL | 50T-XXX-XX | SCALE FULL |
| DESCRIPTION | 10 WATT TERMINATION | TOLERANCES .XX±.010 .XXX±.005 XX°±.5° DWG # |
| | | 092-4885 |