

SPECIFICATION SHEET

JFW MODEL 75DR-021

DUAL ROTARY ATTENUATOR

JFW Industries, Inc.
Phone: 317-887-1340
sales@jfwindustries.com
www.jfwindustries.com

Frequency Range DC-2100 MHz

Impedance 75 Ohms nominal

Attenuation Range 0-30 dB in 1 dB steps

VSWR 1.6:1 maximum

Insertion Loss 1.00 dB maximum
0.55 dB typical @ 1000 MHz
0.75 dB typical @ 2100 MHz

Attenuation Accuracy ± 0.5 dB (1 dB steps)
± 1.0 dB (10 dB steps)

RF Input Power 1 Watt average

Direction of Rotation Attenuation increases in a Clockwise direction

Indexing 30 degrees with stops at minimum and maximum

RF Connector F, BNC, or N female

Operating Temperature Range -20° to +85° C

Lifetime 500,000 attenuation steps (each knob)

Knob/Panel Mounting Drawing 092-8435-02

Outline Drawings 092-2135 (75DR-021 BNC)
092-3579 (75DR-021 N)
092-9371 (75DR-021 F)

ECR/ECN #	DATE	REV	APPR / DATE	ECR/ECN #	DATE	REV	APPR / DATE
20324	07/13/2011	G	TRS 07/13/2011	25776	09/28/2015	J	TRS 09/29/2015
20534	09/06/2011	H	TRS 09/06/2011	28157	10/05/2017	K	TRS 10/05/2017
23479	11/26/2013	I	TRS 11/27/2013	29672	07/24/2019	L	TRS 07/24/2019

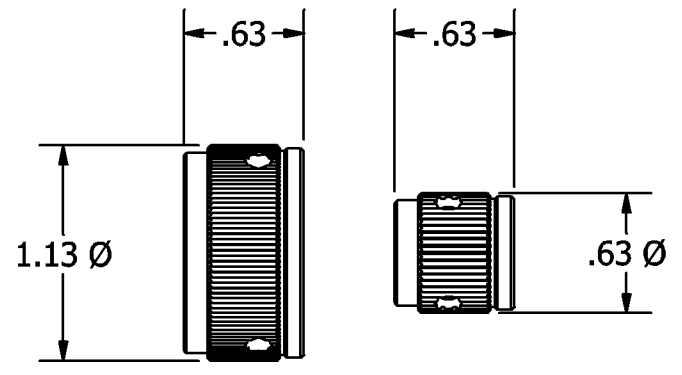
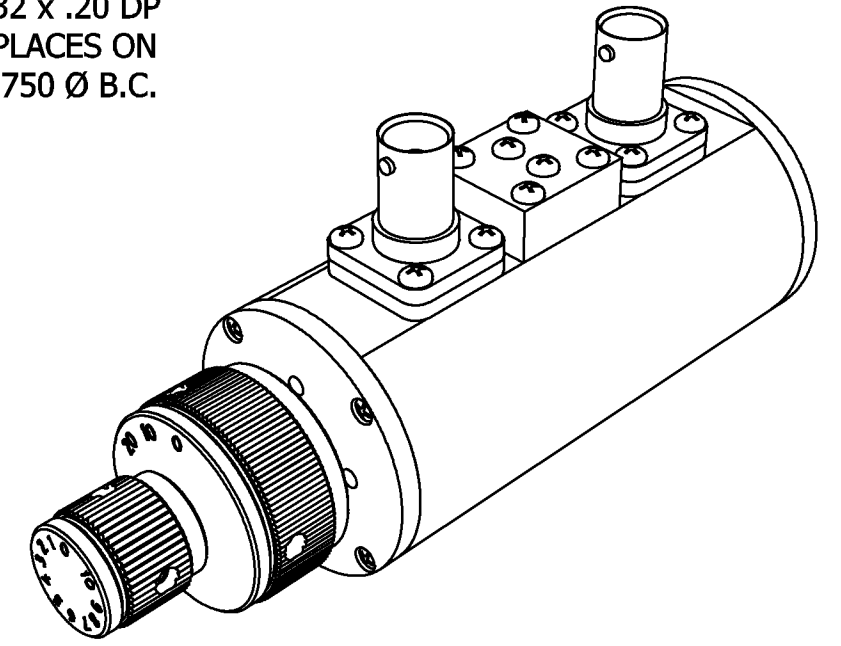
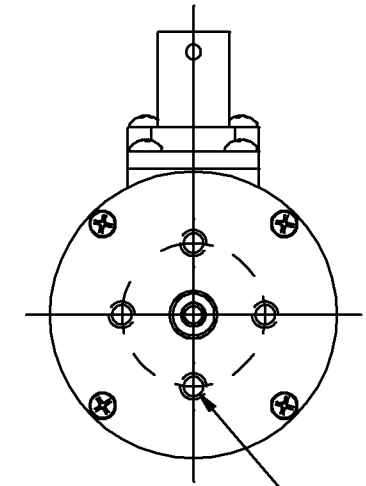
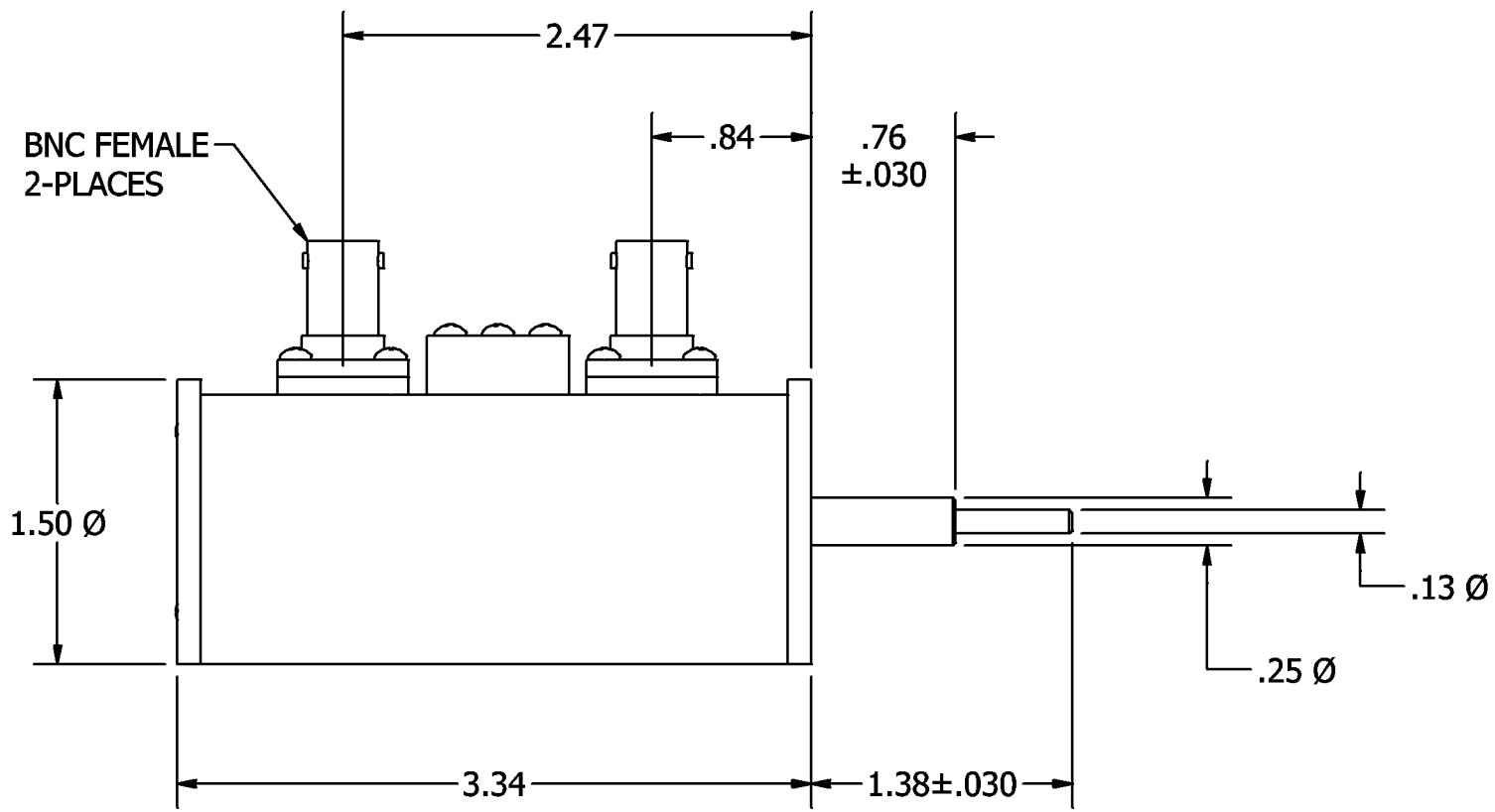

KNOB DETAIL

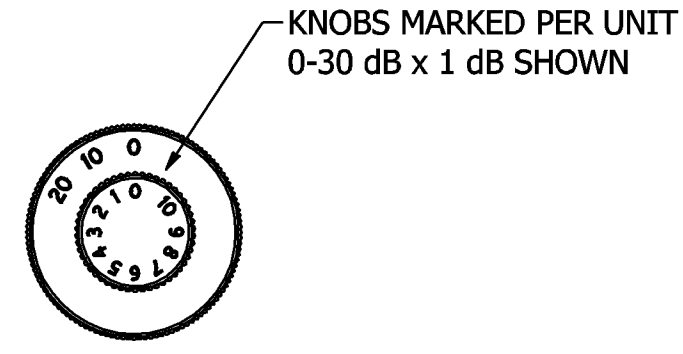

REV	ECN	DATE	BY	APPR	 JFW INDUSTRIES, INC. www.jfwindustries.com PH: 317-887-1340	
-	ISSUED	4-15-93	CDJ	FDW	MATERIAL ALUMINUM ALLOY PROPRIETARY INFORMATION	
A	4612	3-23-95	TEZ	FDW	FINISH CHEMFILM TCP ALL SURFACES ARE TO BE FREE OF BURRS, PITS & SCRATCHES	
B	6601	1-30-01	CDJ	TEZ	TOLERANCES .XX±.010 .XXX±.005 XX°±.5°	
C	6750	6-11-01	CDJ	TEZ	MODEL 75DR-XXX	SCALE FULL
D	6978	1-17-02	MAH	TEZ	DESCRIPTION ROTARY ATTENUATOR	
E	6995	1-30-02	CMB	FDW	DWG # 092-2135	
F	12635	4-20-06	ETW	TEZ		
G	24444	9-17-15	JZ	TEZ		
H	30350	4-27-20	GM	JZ		

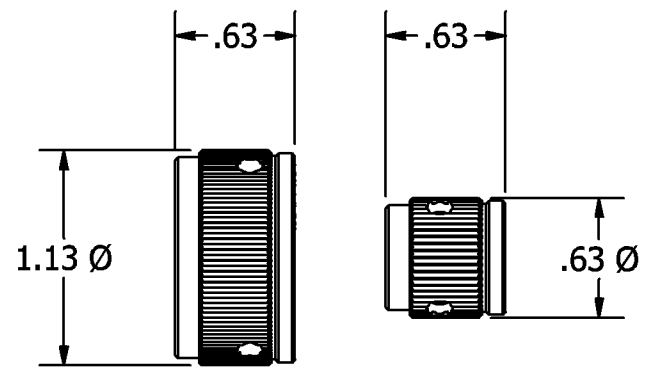
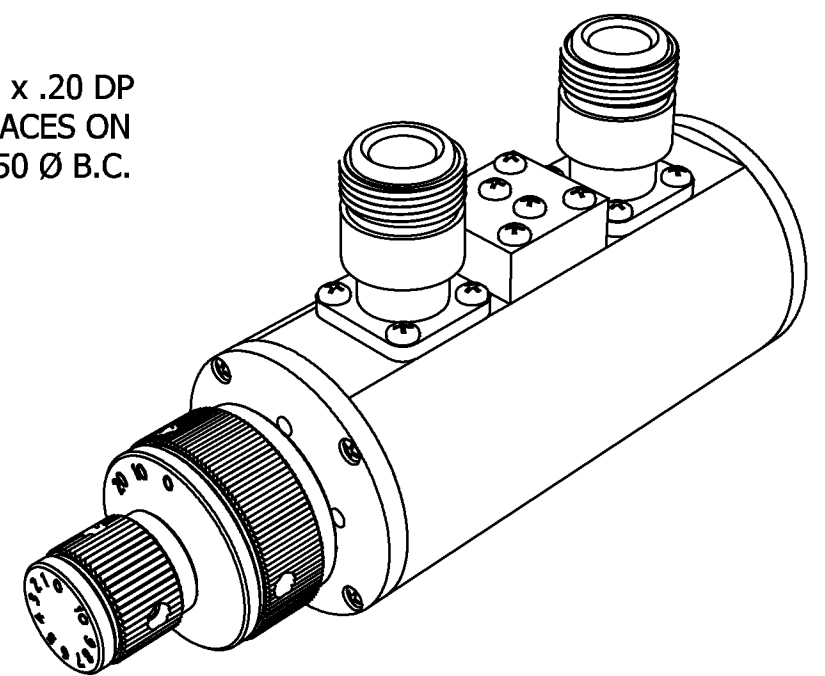
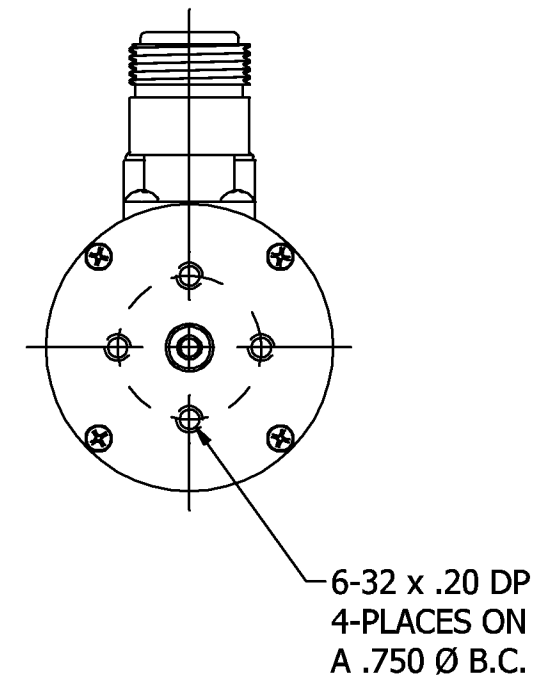
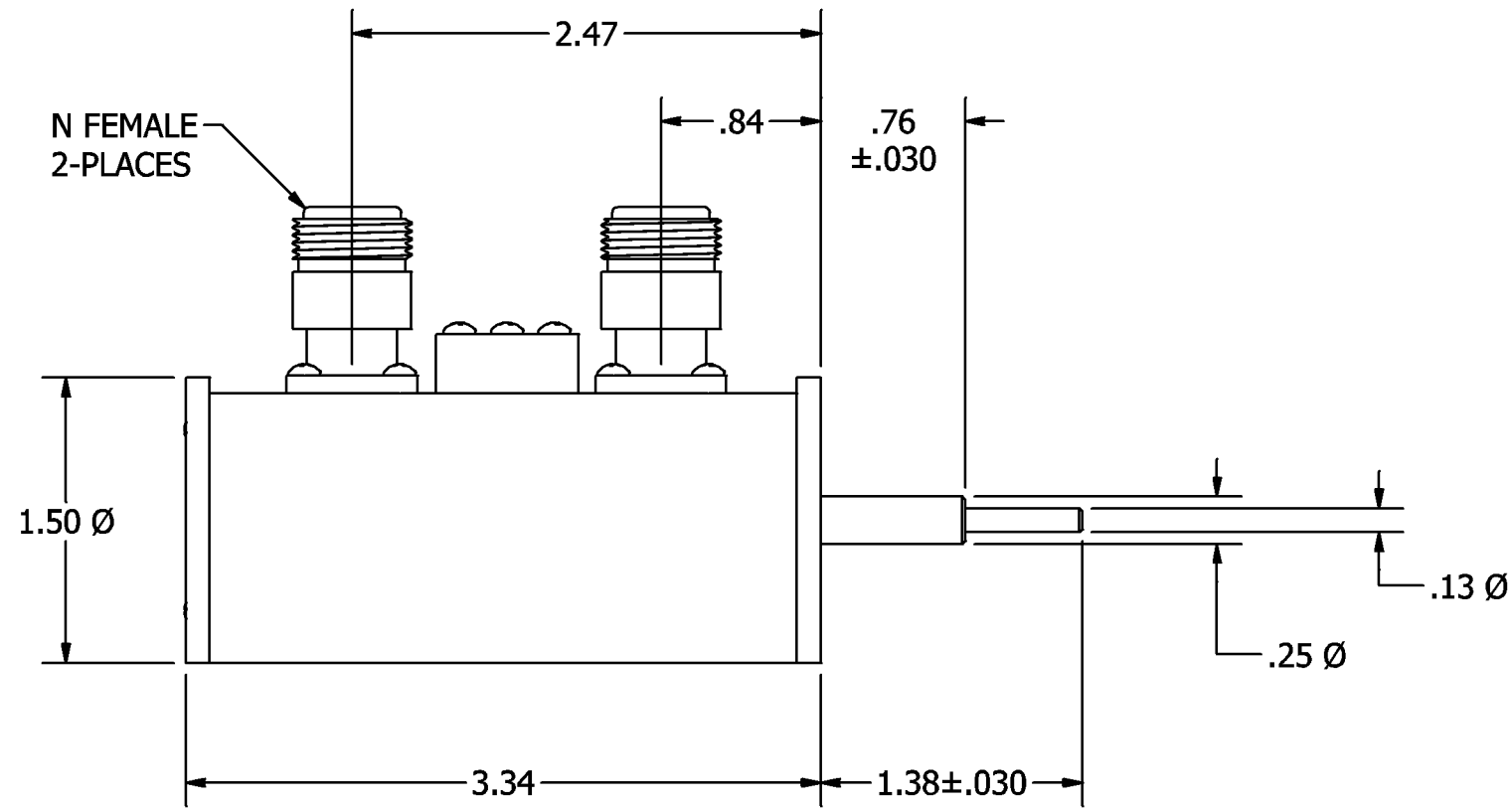

KNOB DETAIL

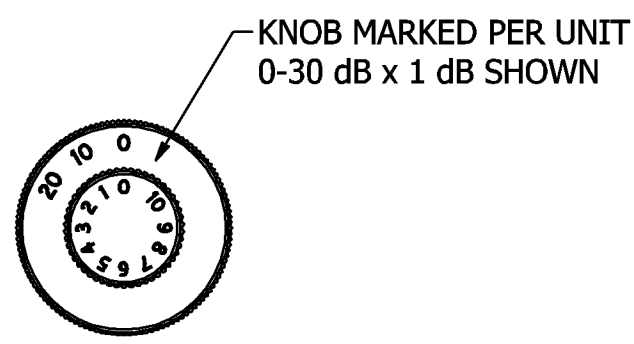

REV	ECN	DATE	BY	APPR	 JFW INDUSTRIES, INC. www.jfwindustries.com PH: 317-887-1340	
-	ISSUED	2-13-01	CDJ	TEZ	MATERIAL	ALUMINUM ALLOY
A	6750	6-11-01	CDJ	TEZ	FINISH	CHEMFILM TCP
B	12635	4-21-06	ETW	TEZ	MODEL	75DR-XXX
C	24444	7-24-19	JZ	TRS	SCALE	FULL
D	30350	4-27-20	GM	JZ	DESCRIPTION	ROTARY ATTENUATOR
					PROPRIETARY INFORMATION	ALL SURFACES ARE TO BE FREE OF BURRS, PITS & SCRATCHES
					TOLERANCES	.XX±.010 .XXX±.005 XX°±.5°
					DWG #	092-3579

