

SPECIFICATION SHEET

JFW MODEL 75R-050

ROTARY ATTENUATOR

JFW Industries, Inc.
Phone: 317-887-1340
sales@jfwindustries.com
www.jfwindustries.com

Frequency Range DC-2200 MHz

Impedance 75 Ohms nominal

Attenuation Range 0-10 dB in 1 dB steps

VSWR 1.3:1 maximum DC-1000 MHz
1.5:1 maximum 1000-2200 MHz

Insertion Loss 0.4 dB maximum DC-1000 MHz
0.6 dB maximum 1000-2200 MHz

Attenuation Accuracy ± 0.3 dB DC-1000 MHz
± 0.4 dB 1000-2200 MHz

RF Input Power 1 Watt average
1000 Watts peak

Direction of Rotation Attenuation increases in a Counter-Clockwise direction

Indexing 30 degrees with stops at minimum and maximum

RF Connector BNC, F or N female

Operating Temperature Range -20°C to +85°C

Lifetime 500,000 attenuation steps

Knob/Panel Mounting Drawing 092-8435-03

Outline Drawings 092-002-01 (75R-050 BNC)
092-002-02 (75R-050 F)
092-002-03 (75R-050 BNC/F)
092-002-04 (75R-050 N)

ECR/ECN #	DATE	REV	APPR / DATE	ECR/ECN #	DATE	REV	APPR / DATE
4494	02/27/2004	E	CLV 02/27/2004	23479	11/26/2013	G	TRS 11/27/2013
9999	05/19/2003	D	BAC 09/29/2003	25779	09/29/2015	H	TRS 09/29/2015
17378	07/02/2009	F	TRS 07/02/2009	28157	10/05/2017	I	TRS 10/05/2017

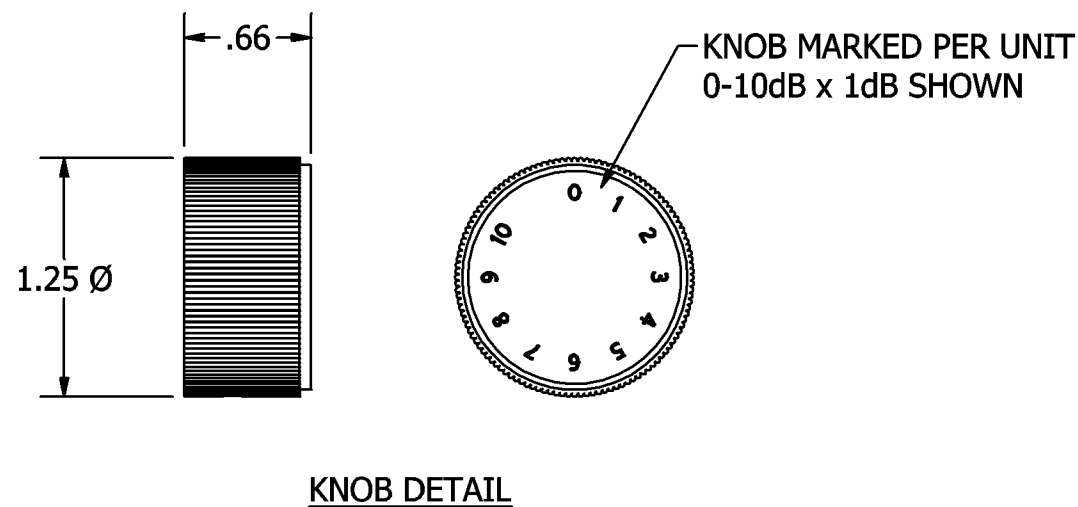
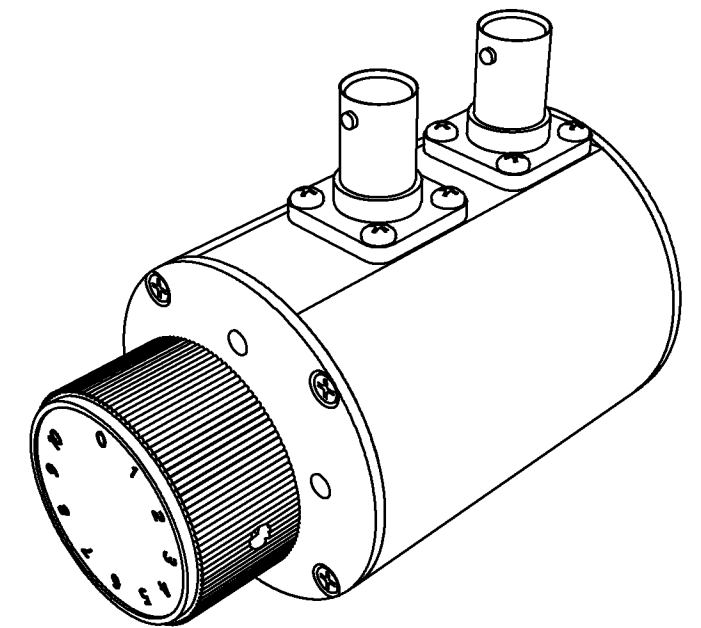
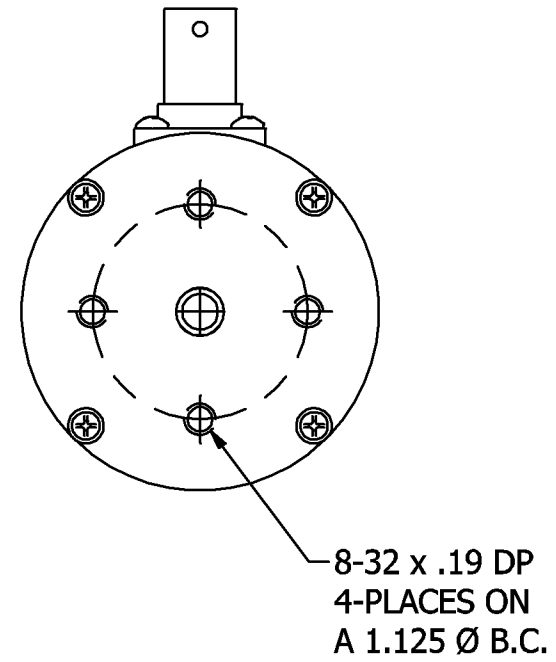
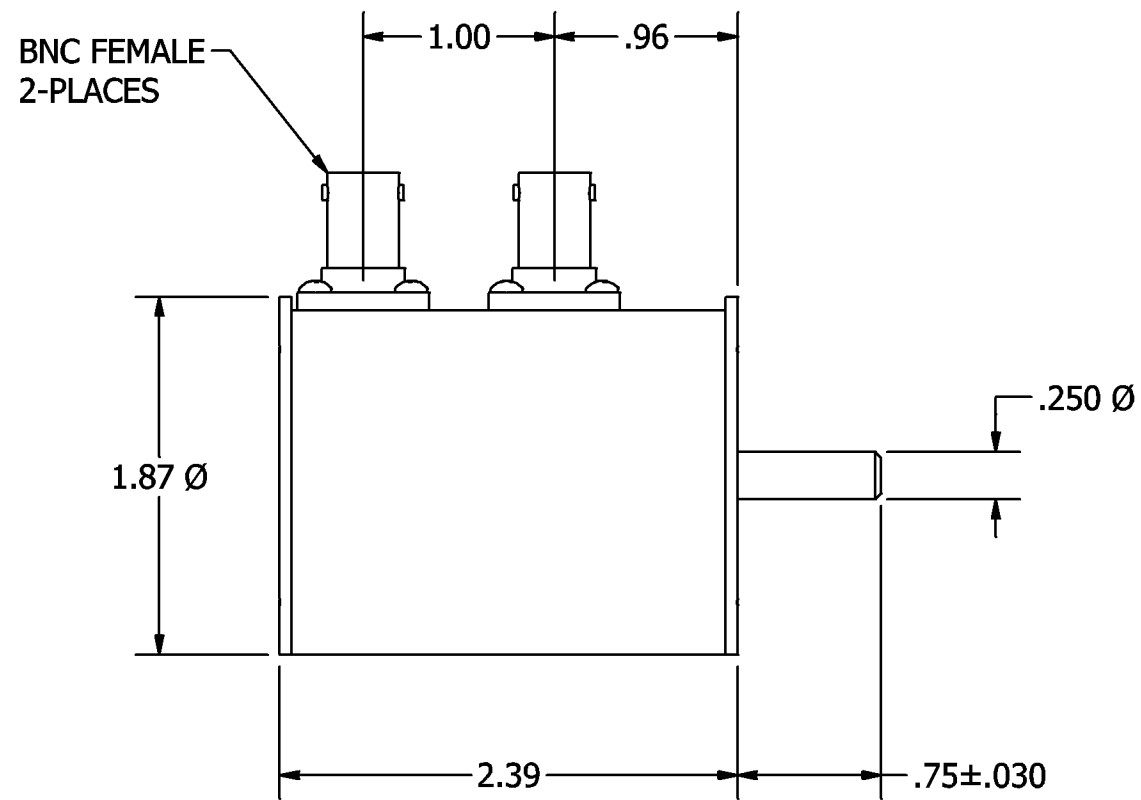

REV	ECN	DATE	BY	APPR
-	ISSUED	6-8-09	BZ	TRS
A	24444	11-20-15	JZ	TEZ
B	30350	4-27-20	GM	JZ



JFW INDUSTRIES, INC.

www.jfwindustries.com

PH: 317-887-1340

MATERIAL	ALUMINUM ALLOY	PROPRIETARY INFORMATION
FINISH	CHEMFILM TCP	ALL SURFACES ARE TO BE FREE OF BURRS, PITS & SCRATCHES
MODEL	75R-XXX	TOLERANCES .XX±.010 .XXX±.005 XX°±.5°
DESCRIPTION	ROTARY ATTENUATOR	DWG #
		092-002-01

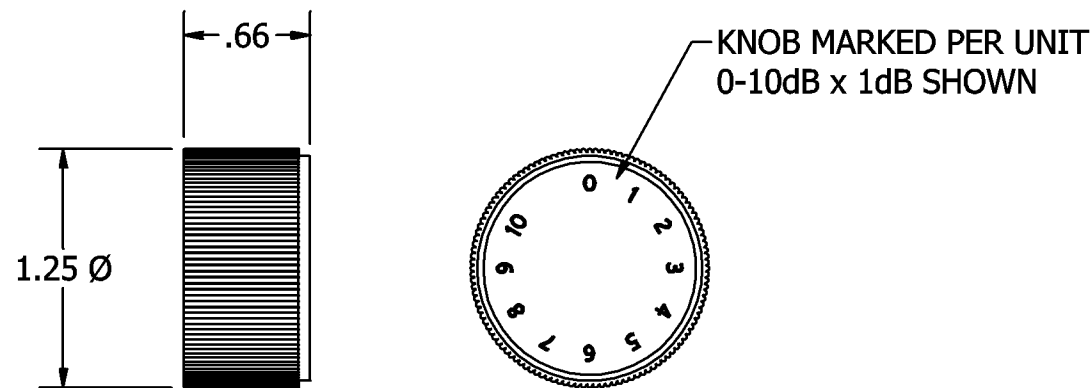
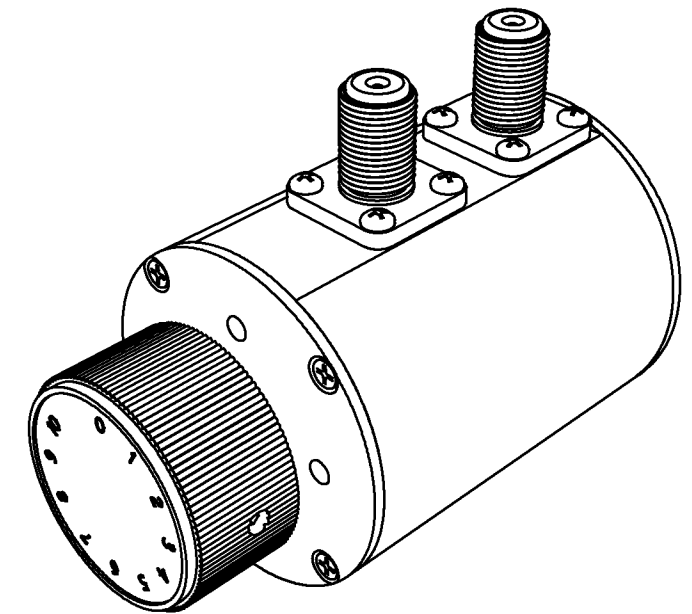
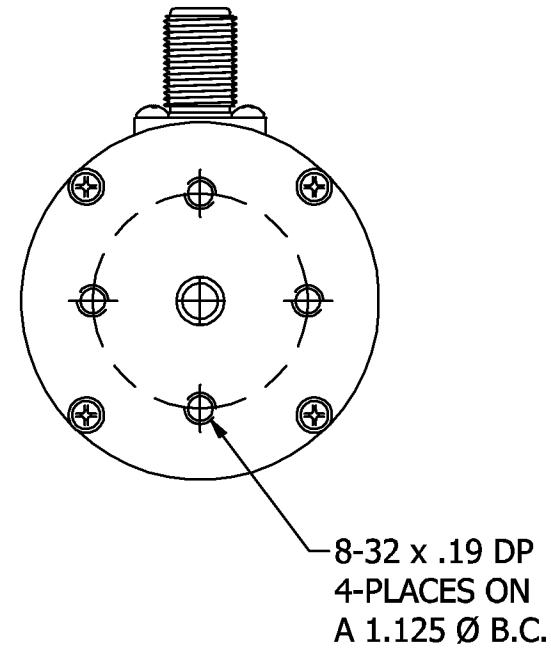
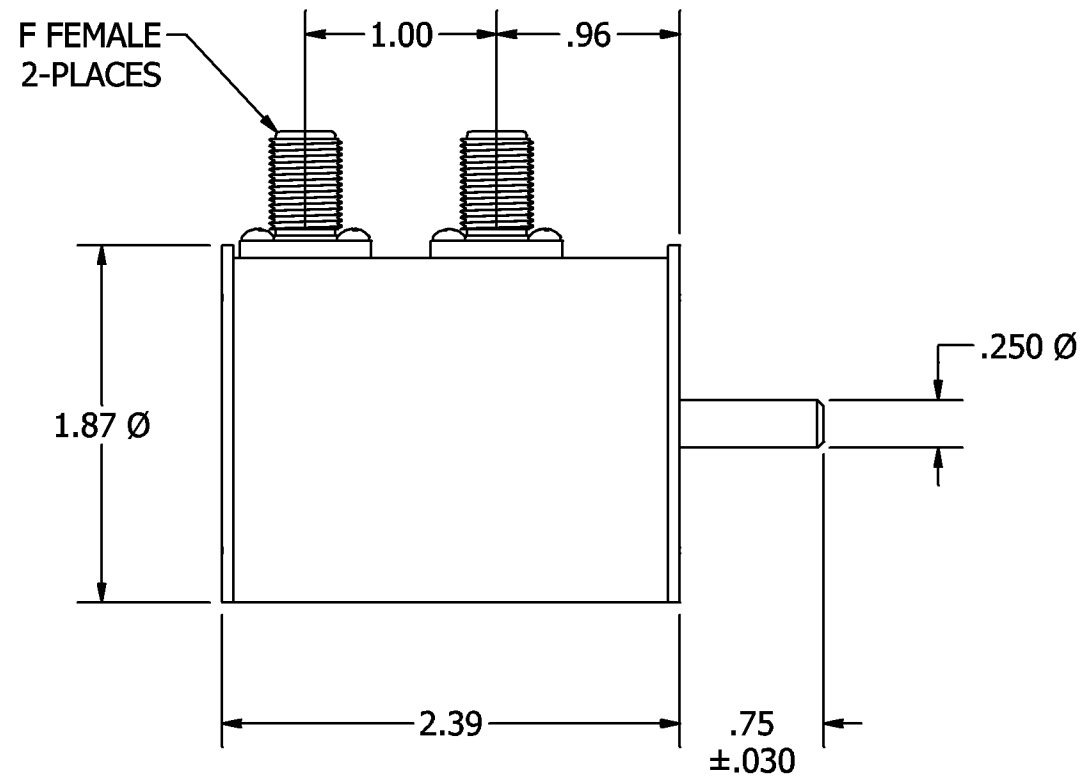

KNOB DETAIL

REV	ECN	DATE	BY	APPR
-	ISSUED	6-8-09	BZ	TRS
A	24444	11-20-15	JZ	TRS
B	30350	4-27-20	GM	JZ



JFW INDUSTRIES, INC.

www.jfwindustries.com

PH: 317-887-1340

MATERIAL	ALUMINUM ALLOY	PROPRIETARY INFORMATION
FINISH	CHEMFILM TCP	ALL SURFACES ARE TO BE FREE OF BURRS, PITS & SCRATCHES
MODEL	75R-XXX	TOLERANCES .XX±.010 .XXX±.005 XX°±.5°
DESCRIPTION	ROTARY ATTENUATOR	DWG #
		092-002-02

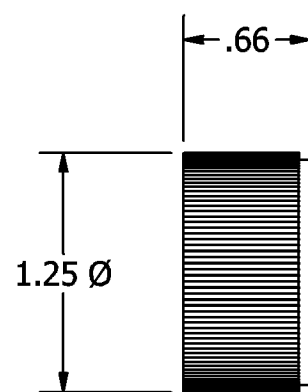
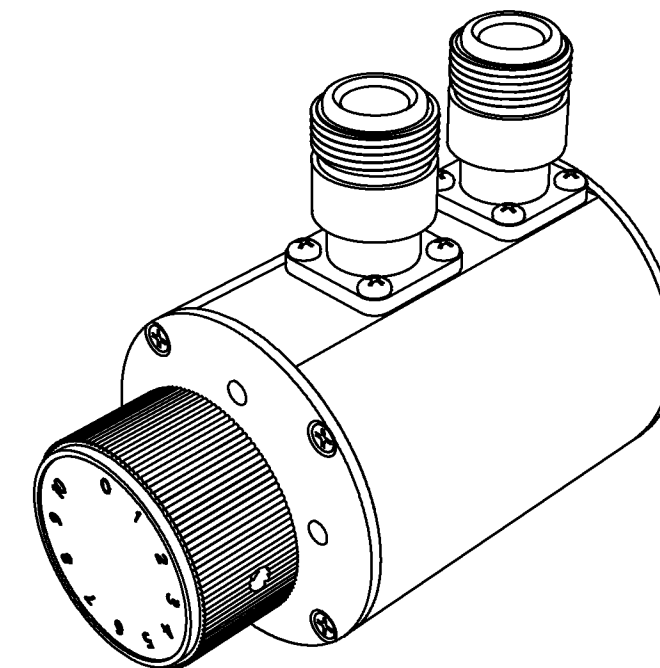
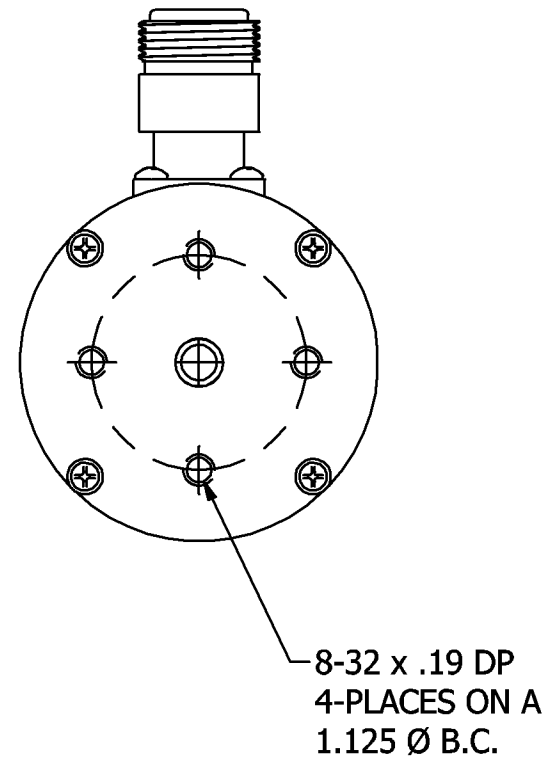
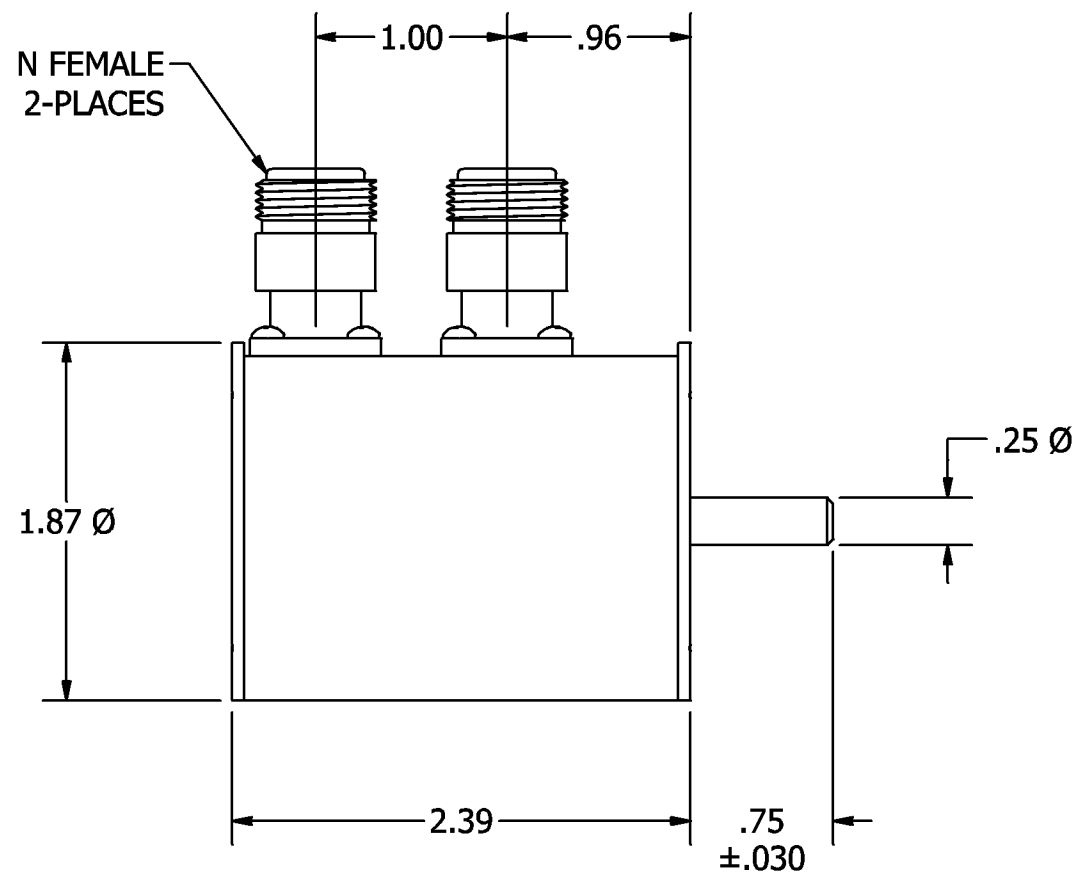

KNOB DETAIL

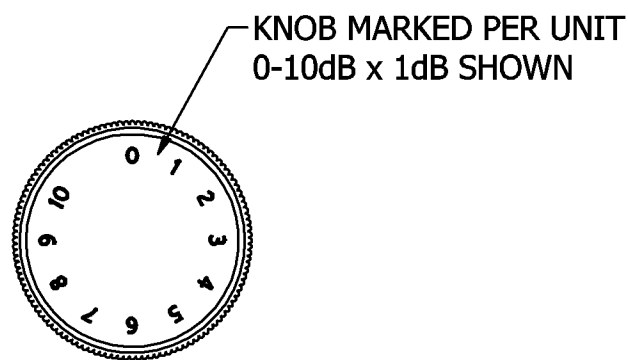

REV	ECN	DATE	BY	APPR
-	ISSUED	6-8-09	BZ	TRS
A	24444	9-3-19	GM	JZ
B	30350	4-27-20	GM	XX



JFW INDUSTRIES, INC.

www.jfwindustries.com

PH: 317-887-1340

MATERIAL	ALUMINUM ALLOY	PROPRIETARY INFORMATION
FINISH	CHEMFILM TCP	ALL SURFACES ARE TO BE FREE OF BURRS, PITS & SCRATCHES
MODEL	XXR-XXX	TOLERANCES .XX±.010 .XXX±.005 XX°±.5°
DESCRIPTION	ROTARY ATTENUATOR	DWG #
		092-002-04

