

SPECIFICATION SHEET

JFW MODEL 75R-055

ROTARY ATTENUATOR

JFW Industries, Inc.
Phone: 317-887-1340
sales@jfwindustries.com
www.jfwindustries.com

Frequency Range DC-1000 MHz

Impedance 75 Ohms nominal

Attenuation Range 0-70 dB in 10 dB steps

VSWR 1.3:1 maximum DC-500 MHz
1.5:1 maximum 500-1000 MHz

Insertion Loss 0.4 dB maximum

Attenuation Accuracy ± 0.75 dB DC-500 MHz
± 1.00 dB 500-1000 MHz

RF Input Power 1 Watt average
1000 Watts peak

Direction of Rotation Attenuation increases in a Counter-
Clockwise direction

Indexing 30 degrees with stops at minimum and
maximum

RF Connector BNC, N or F female

Operating Temperature Range -20°C to +85°C

Lifetime 500,000 attenuation steps

Knob/Panel Mounting Drawing 092-8435-03

Outline Drawings 092-003-01 (75R-055 BNC)
092-003-02 (75R-055 F)
092-003-03 (75R-055 BNC/F)
092-003-04 (75R-055 N)

ECR/ECN #	DATE	REV	APPR / DATE	ECR/ECN #	DATE	REV	APPR / DATE
9999	05/19/2003	A	BAC 02/05/2004	19437	12/01/2010	D	TRS 12/01/2010
17378	07/02/2009	B	TRS 07/02/2009	25779	09/29/2015	E	TRS 09/29/2015
18656	05/14/2010	C	TRS 05/14/2010	28157	10/05/2017	F	TRS 10/05/2017

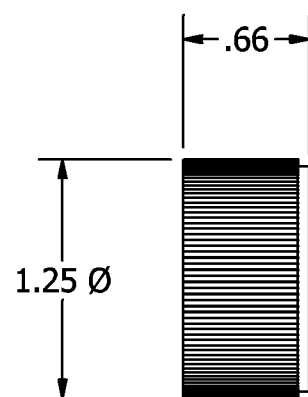
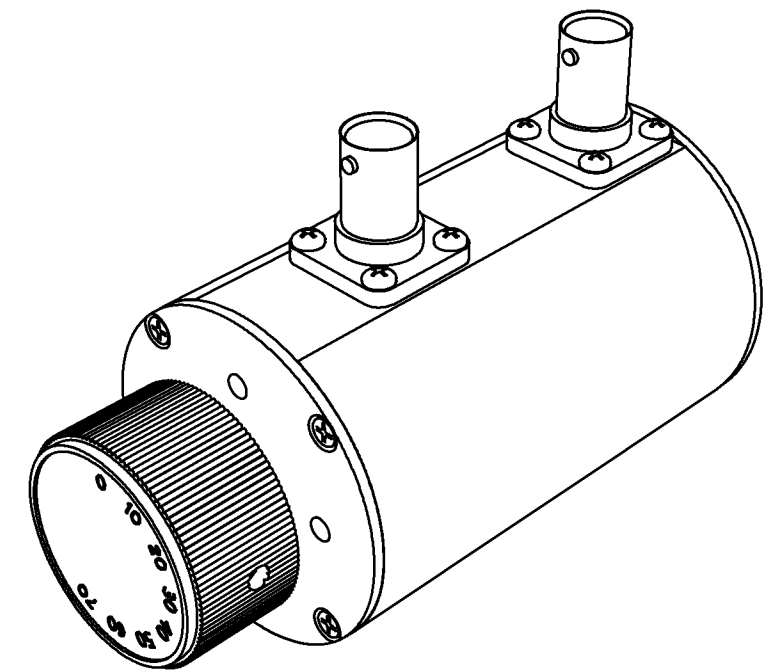
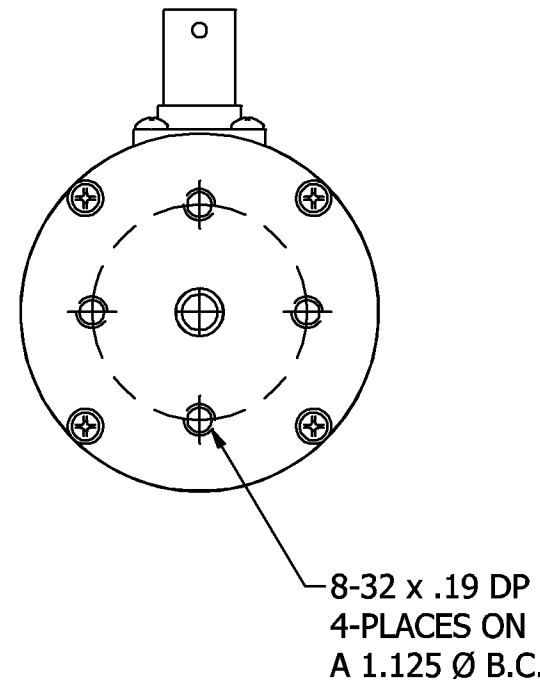
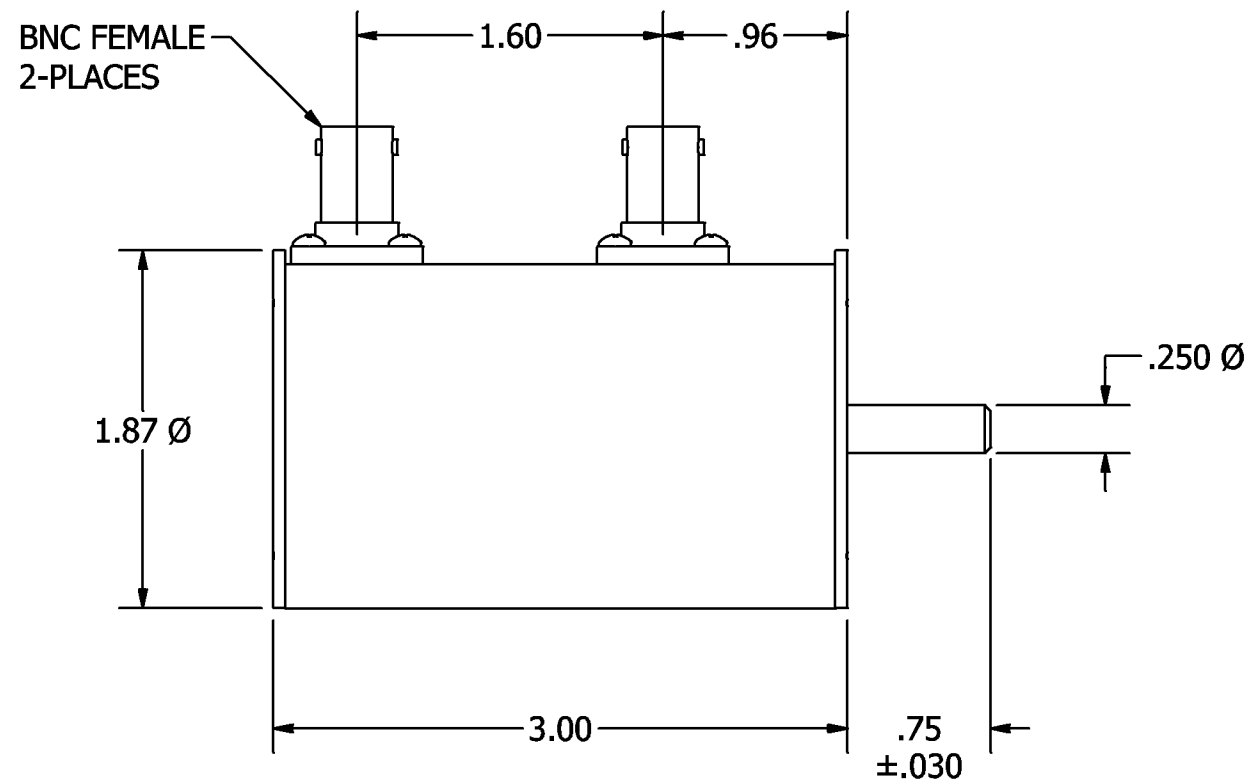

KNOB DETAIL

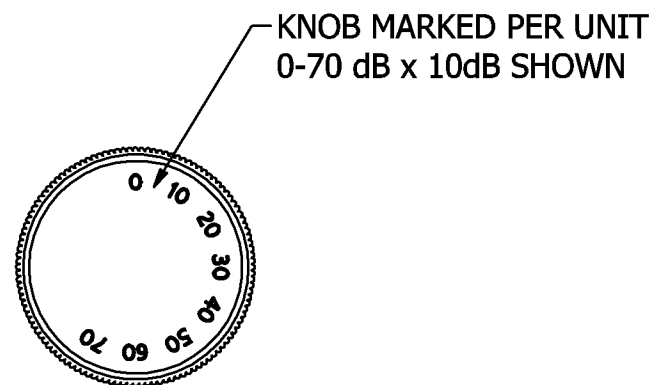

REV	ECN	DATE	BY	APPR
-	ISSUED	6-8-09	BZ	TRS
A	24444	11-20-15	JZ	TEZ
B	30350	4-27-20	GM	JZ



JFW INDUSTRIES, INC.

www.jfwindustries.com

PH: 317-887-1340

MATERIAL	ALUMINUM ALLOY	PROPRIETARY INFORMATION
FINISH	CHEMFILM TCP	ALL SURFACES ARE TO BE FREE OF BURRS, PITS & SCRATCHES
MODEL	75R-XXX	TOLERANCES .XX±.010 .XXX±.005 XX°±.5°
DESCRIPTION	ROTARY ATTENUATOR	DWG #
		092-003-01

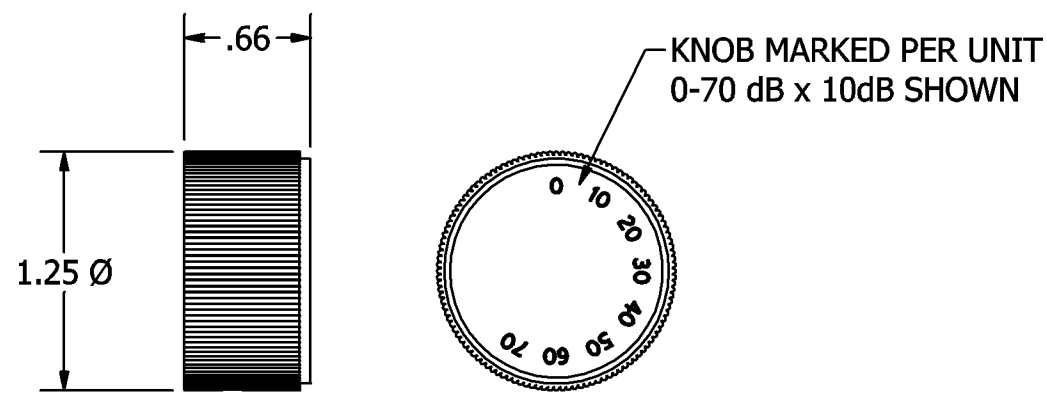
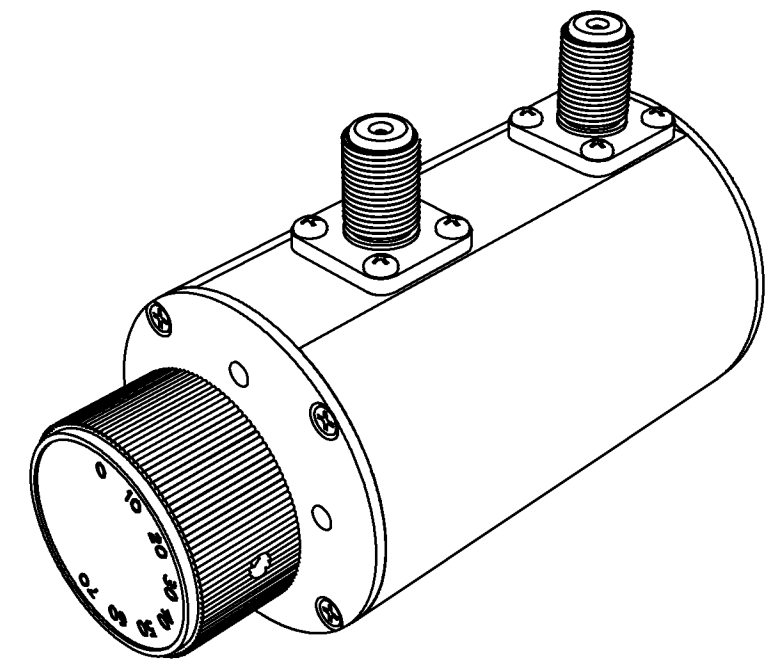
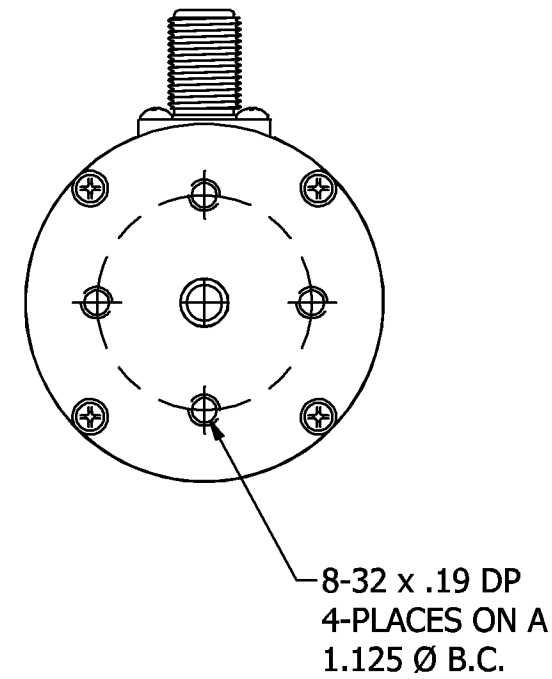
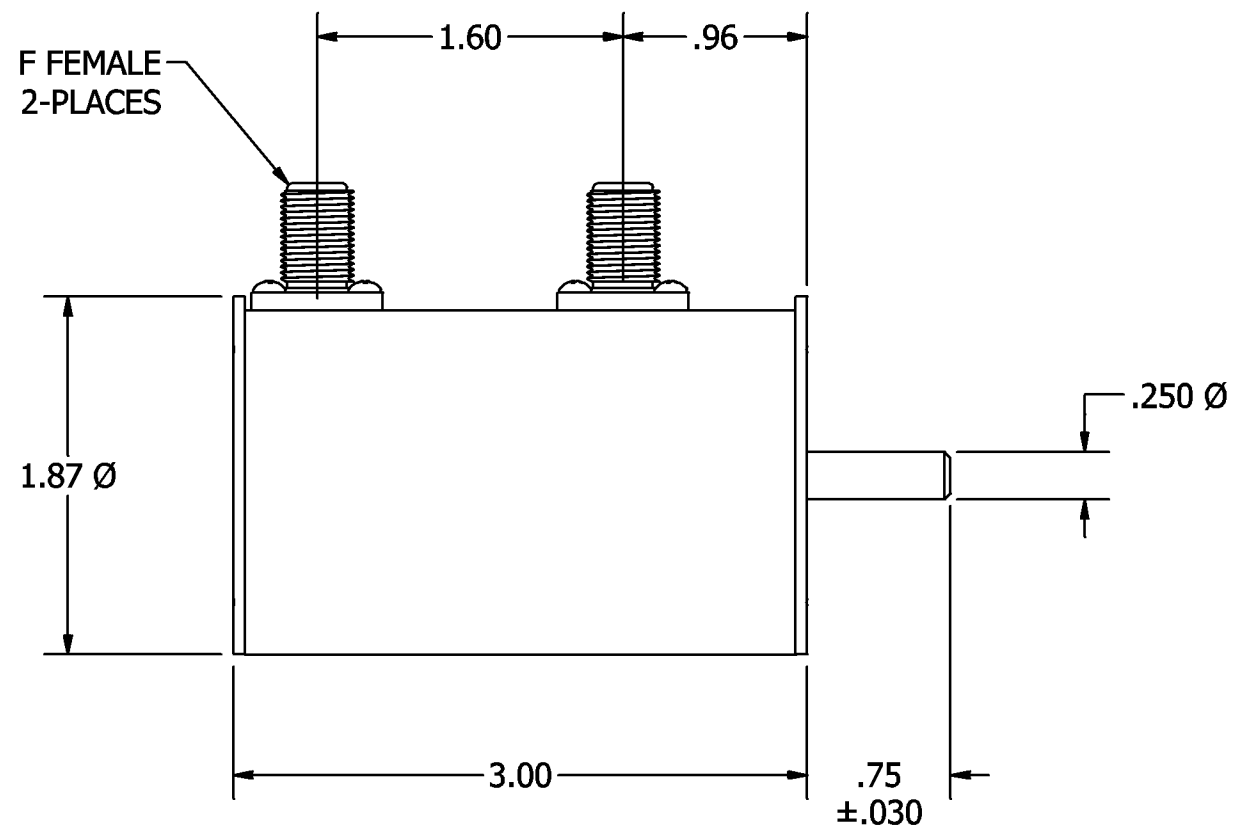

KNOB DETAIL

REV	ECN	DATE	BY	APPR
-	ISSUED	6-8-09	BZ	TRS
A	24444	9-3-19	GM	JZ
B	30350	4-27-20	GM	JZ



JFW INDUSTRIES, INC.

www.jfwindustries.com

PH: 317-887-1340

MATERIAL	ALUMINUM ALLOY	PROPRIETARY INFORMATION
FINISH	CHEMFILM TCP	ALL SURFACES ARE TO BE FREE OF BURRS, PITS & SCRATCHES
MODEL	XXR-XXX	TOLERANCES .XX±.010 .XXX±.005 XX°±.5°
DESCRIPTION	ROTARY ATTENUATOR	DWG #
		092-003-02

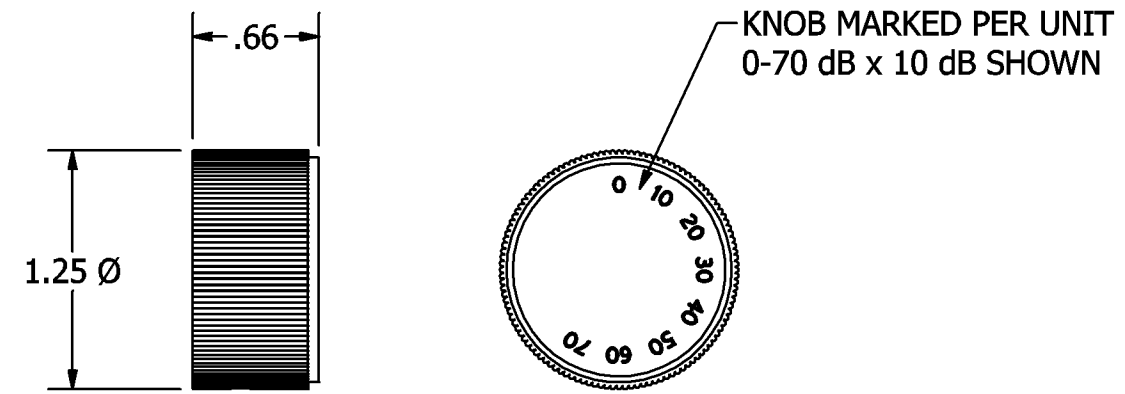
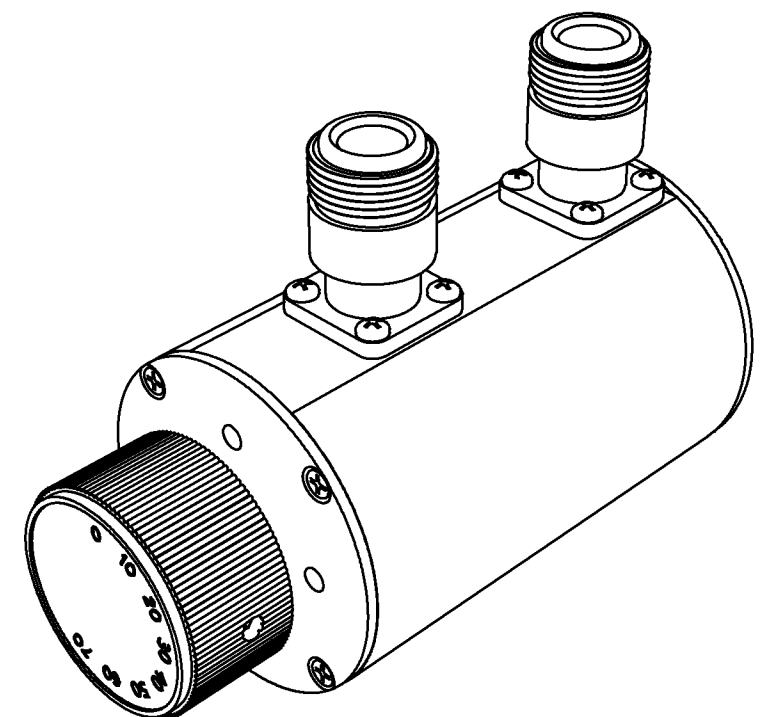
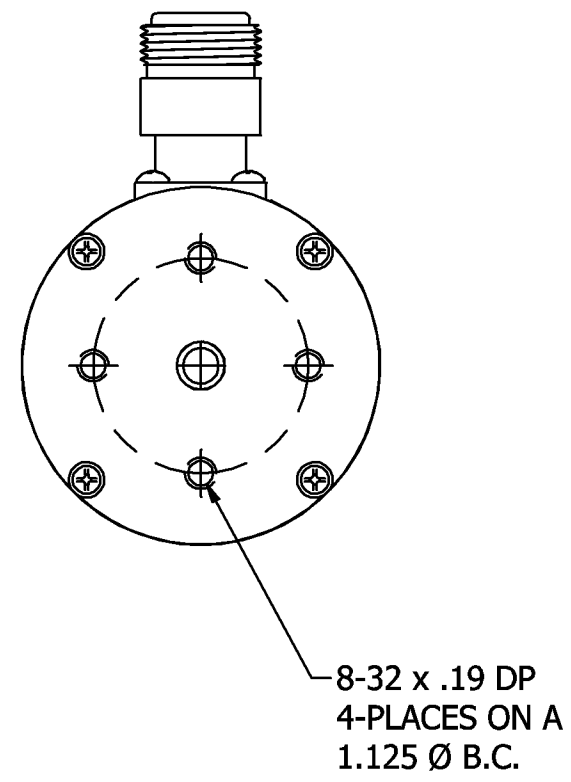
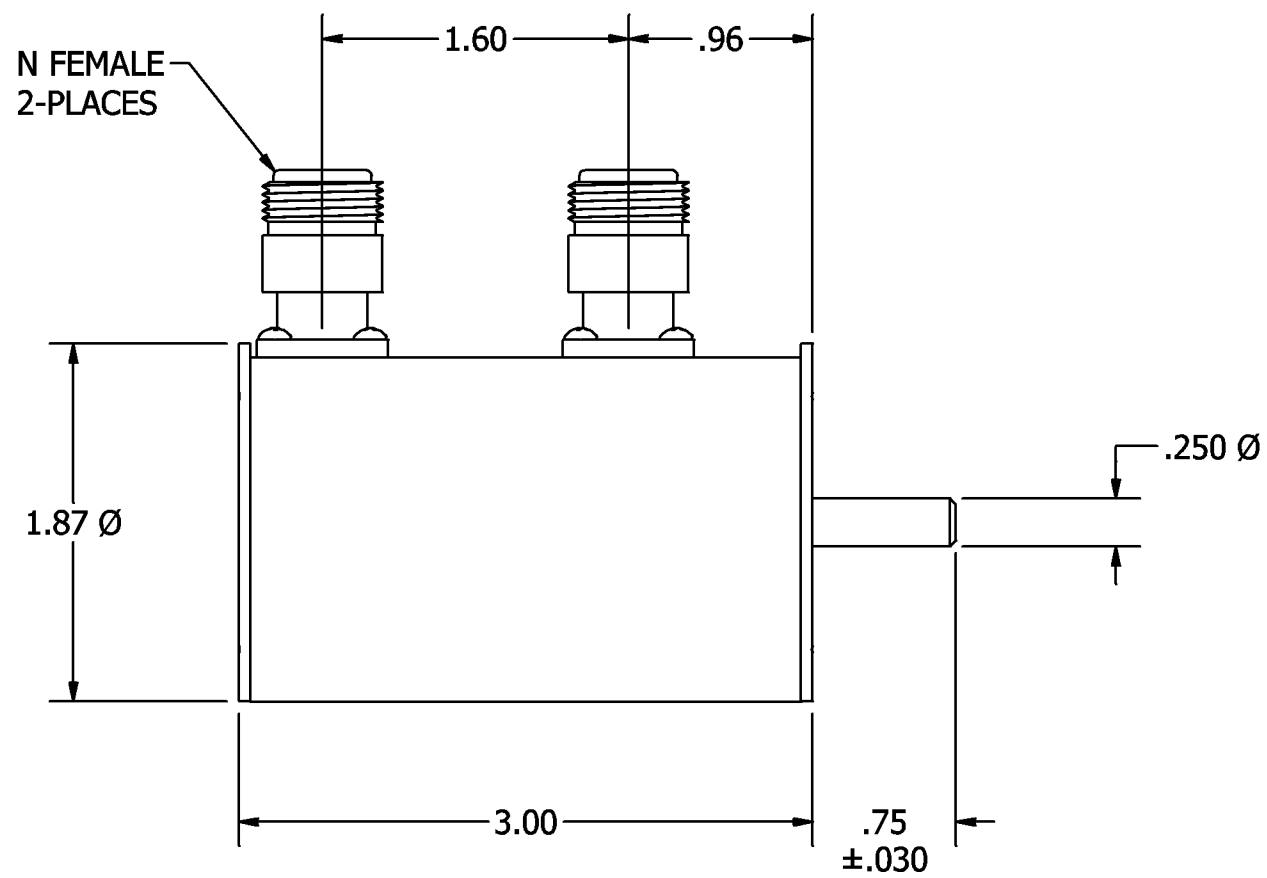

KNOB DETAIL

REV	ECN	DATE	BY	APPR	 JFW INDUSTRIES, INC. www.jfwindustries.com PH: 317-887-1340	
-	ISSUED	6-8-09	BZ	TRS	PROPRIETARY INFORMATION	
A	24444	9-4-19	GM	JZ	ALL SURFACES ARE TO BE FREE OF BURRS, PITS & SCRATCHES	
B	30350	4-27-20	GM	JZ	TOLERANCES .XX±.010 .XXX±.005 XX°±.5°	
MATERIAL					ALUMINUM ALLOY	DWG #
FINISH					CHEMFILM TCP	
MODEL					XXR-XXX	SCALE FULL
DESCRIPTION					ROTARY ATTENUATOR	092-003-04

