

SMP Interconnect Series



INTRODUCTION

Carlisle Interconnect Technologies launched the SMP “push-on” connector product line about two decades ago to facilitate dense packaging within RF/Microwave systems. The SMP interface has enabled design engineers to increase performance and complexity of their designs and improve upon their form factor.

The SMP interconnect series relies on a floating female-to-female adapter—commonly referred to as a “bullet”—to enable stacking of boards equipped with an SMP male PCB connector. This durable construction and ability to tolerate radial and axial misalignment allows for a blind-mate interconnect solution. SMP connectors can also withstand multiple engagement/disengagement cycles without degradation in electrical performance.

The success of the SMP product line has spurred the development and commercialization of other blind-mate interconnect systems – namely the SSMP®, TMP® and WMP® to facilitate rapid assembly and testing for the gamut of Military and Commercial RF/Microwave applications.

MATERIALS & FINISH

Metal	Specification
BeCu (Beryllium Copper)	ASTM B 196 and/or ASTM B 197
Brass	ASTM B 36, B121, B16, B16M
Stainless Steel	ASTM A484/ A582 or A555/581
Iron-Nickel-Cobalt	ASTM F-15
Dielectric	Specification
Virgin PTFE Fluorocarbon	ASTM D 1710 and ASTM D 1457
Polyamide-imide	ASTM D5204 Group 2 Class 1
Glass	Corning 7070 or Equivalent
Finish	Specification
Gold (75u in. Typ)	ASTM-B488 Type 1, Class 1.25
Nickel (100u in. Typ)	SAE AMS-QQ-N-290
Passivation	ASTM A967

FEATURES

- » Frequency Range: DC - 40 GHz
- » 50 Ω Impedance; Blindmateable configuration
- » Industry standard per MIL-STD-348
- » MIL-PRF-39012 compliant
- » Ability to withstand Radial/Axial Misalignment
- » Board-mount, Field-replaceable, Bullets, Hermetic and Cable Connector configurations
- » Custom Connectors Available

SPECIFICATIONS

Parameter	Specification	
Impedance	50 Ω	
Frequency range	DC - 40 GHz	
VSWR	DC - 26 GHz: 1.15 : 1 (max) 26 - 40 GHz: 1.40:1 (max)	
Insertion Loss	0.1 x √ f (GHz)	
DWV @ Sea Level	500 Vrms	
Insulation Resistance	5000 MΩ (min)	
RF High Pot	325 Vrms @ 5 MHz	
Force to Engage	Full Detent	15 lbs typical
	Limited Detent	7 lbs typical
	Smooth Bore	2 lbs typical
Force to Disengage	Full Detent	5 lbs typical
	Limited Detent	3 lbs typical
	Smooth Bore	0.5 lbs typical
Radial Misalignment	+/- .020 inches*	
Axial Misalignment	.010 inches	
Temperature range	-55° C to +165° C	
Thermal Shock	MIL-STD-202, Method 107, Cond B	
Moisture Resistance	MIL-STD-202, Method 106, except step 7b	
Corrosion	MIL-STD-202, Method 101, Cond B	
Vibration	MIL-STD-202, Method 204, Cond D	
Shock	MIL-STD-202, Method 213, Cond I	

*When mated to a Catcher's Mitt interface

SMP Configurations

CABLE CONNECTORS - FOR FLEXIBLE CABLES

SMP Female Straight Connector for Flexible Cables / P657

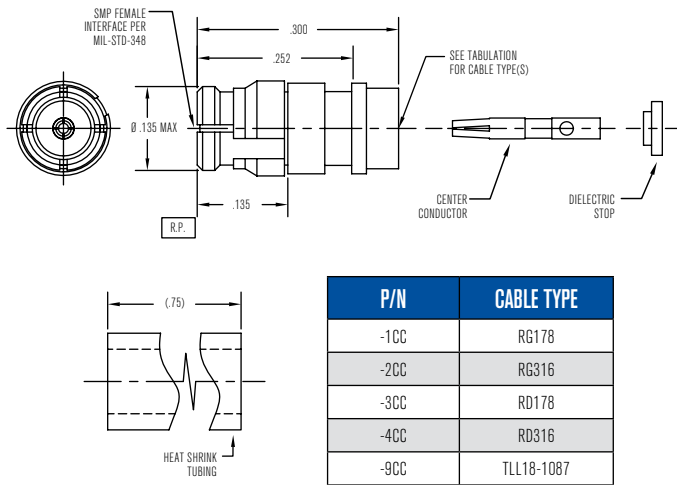

P/N	CABLE TYPE
-1CC	RG178
-2CC	RG316
-3CC	RD178
-4CC	RD316
-9CC	TLL18-1087

SMP Female Right Angle Connector for Flexible Cables, 18 GHz / P600

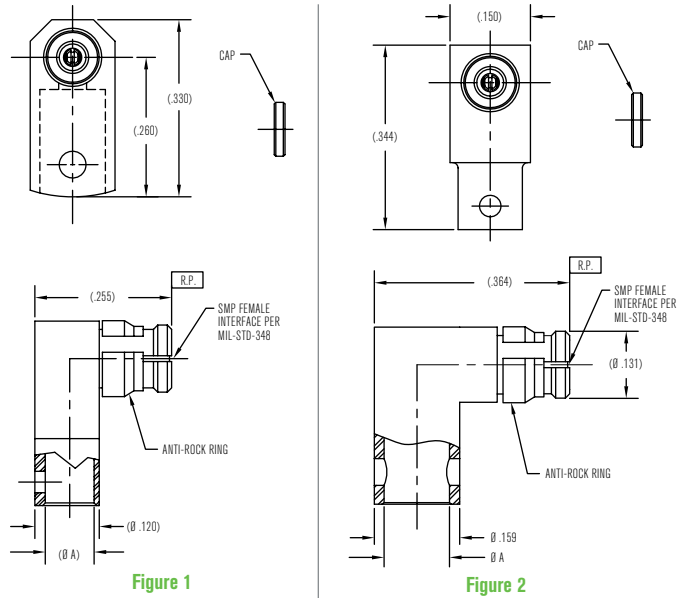

P/N	(Ø A)	CABLE TYPE	FIGURE
-9CC	(.090)	TLL18-1087	1
-11CC	(.122)	TLL40-1111A	2

SMP Female Right Angle Connector for Flexible Cables, 26.5 GHz / P601

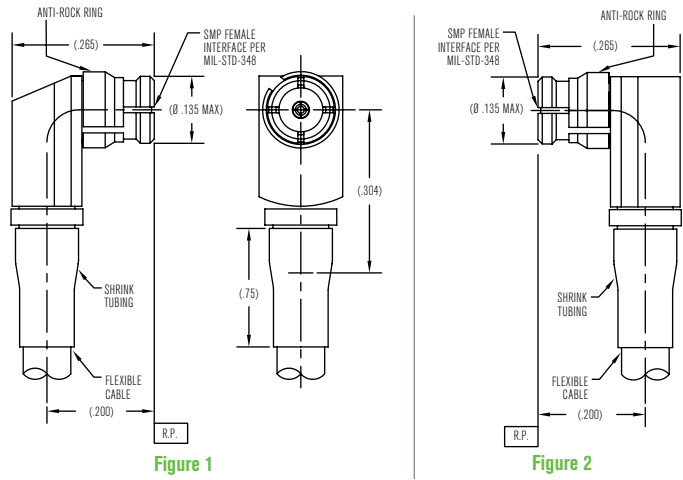

P/N	(Ø A)	CABLE TYPE	FIGURE
-9CC	(.090)	TLL18-1087	1
-11CC	(.122)	TLL40-1111A	2

SMP Male Straight Panel Mount Connector for Flexible Cables / P663

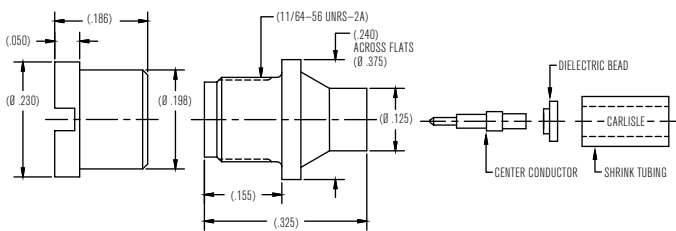
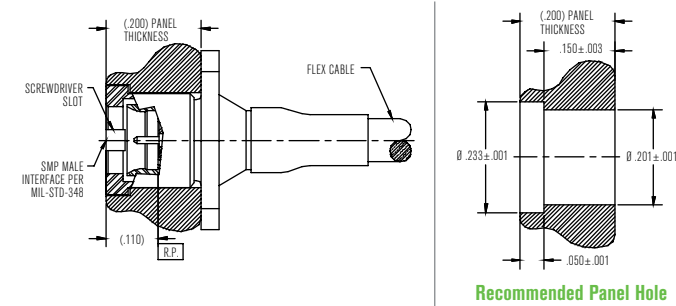

P/N	CABLE TYPE	INTERFACE
-1CC	M17/93-RG178 (OR EQUIVALENT)	CATCHER'S MITT
-2CC	RD178 (OR EQUIVALENT)	CATCHER'S MITT
-3CC	M17/113-RG316 (OR EQUIVALENT)	CATCHER'S MITT
-4CC	RD316 (OR EQUIVALENT)	CATCHER'S MITT
-5CC	M17/93-RG178 (OR EQUIVALENT)	LIMITED DETENT
-6CC	RD178 (OR EQUIVALENT)	LIMITED DETENT

P/N	CABLE TYPE	INTERFACE
-7CC	M17/113-RG316 (OR EQUIVALENT)	LIMITED DETENT
-8CC	RD316 (OR EQUIVALENT)	LIMITED DETENT
-9CC	M17/93-RG178 (OR EQUIVALENT)	FULL DETENT
-10CC	RD178 (OR EQUIVALENT)	FULL DETENT
-11CC	M17/113-RG316 (OR EQUIVALENT)	FULL DETENT
-12CC	RD316 (OR EQUIVALENT)	FULL DETENT

CABLE CONNECTORS - FOR SEMI-RIGID & SEMI-FLEX CABLES

SMP Female Straight Connector for Semi-Rigid and Semi-Flex Cables / P651

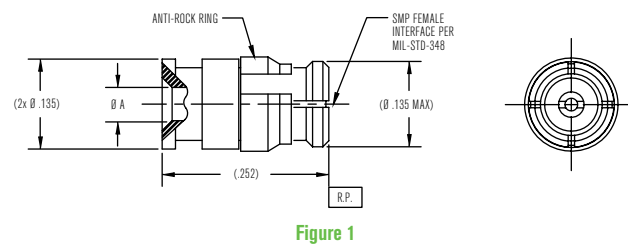

Figure 1

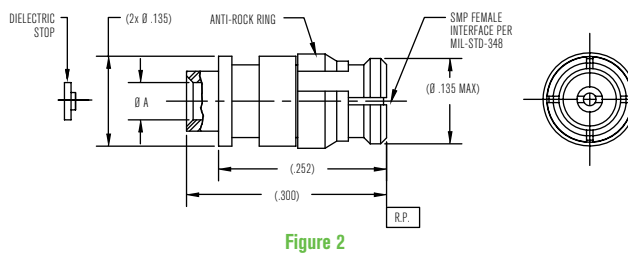
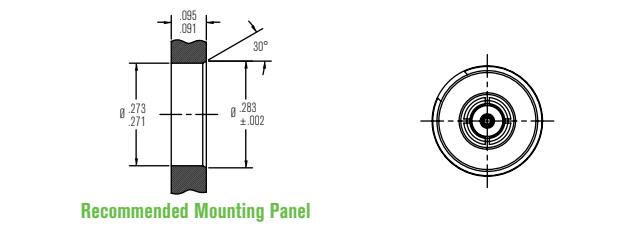

Figure 2

P/N	CABLE TYPE	(Ø A)	FIGURE
-1CC	Ø .047 SEMI-RIGID CABLE	.049 MIN	2
-2CC	Ø .085 SEMI-RIGID CABLE	.085 MIN	1
-3CC	Ø .047 MICROPOROUS CABLE	.047 MIN	2
-4CC	Ø .085 MICROPOROUS CABLE	.085 MIN	1

SMP Female Float Mount Connector for Semi-Rigid and Semi-Flex Cables / P658



Recommended Mounting Panel

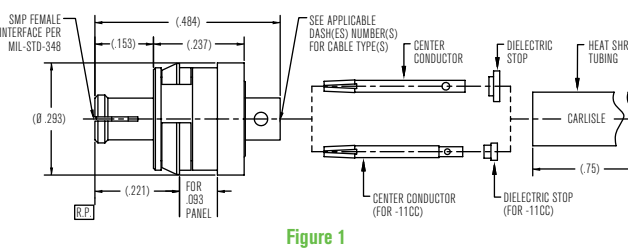

Figure 1

SMP Female Float Mount Connector for Semi-Rigid and Semi-Flex Cables / P658 (Continued)

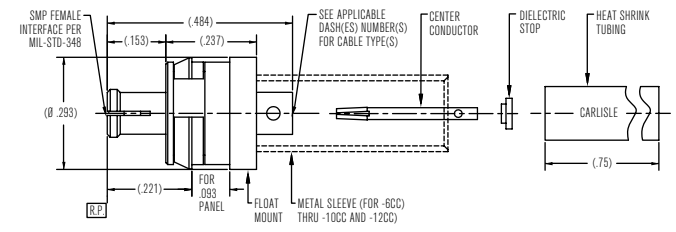
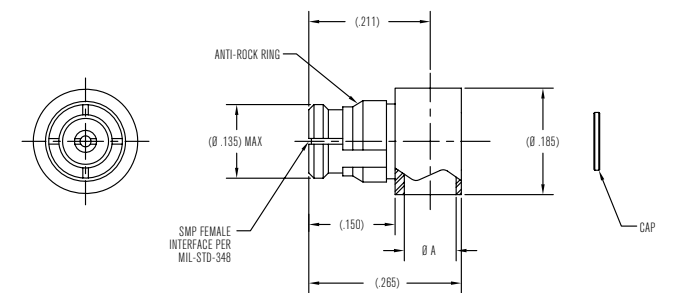

Figure 2

P/N	CABLE TYPE	FIGURE
-1CC	UFF Ø .092A	1
-2CC	M17/113-RG316	
-3CC	TLL40-1087	
-4CC	MICROFLEX Ø .095	
-5CC	Ø .085 SEMI-RIGID	
-6CC	UFF Ø .092A	2
-7CC	M17/113-RG316	
-8CC	TLL40-1087	
-9CC	MICROFLEX Ø .095	
-10CC	Ø .085 SEMI-RIGID	
-11CC	Ø .047 SEMI-RIGID	1
-12CC	Ø .047 SEMI-RIGID	2

SMP Female Right Angle For Semi-Rigid/Semi-Flex Cables, 12 GHz / P652



P/N	Ø A	CABLE TYPE
-1CC	.049 MIN	.047 SEMI-RIGID
-2CC	.088 MIN	.085 SEMI-RIGID
-3CC	.049 MIN	.047 MICROPOROUS
-4CC	.088 MIN	.085 MICROPOROUS

SMP Configurations

CABLE CONNECTORS - FOR SEMI-RIGID & SEMI-FLEX CABLES (CONT.)

SMP Female Right Angle For Semi-Rigid/Semi-Flex Cables, 26.5 GHz / P655

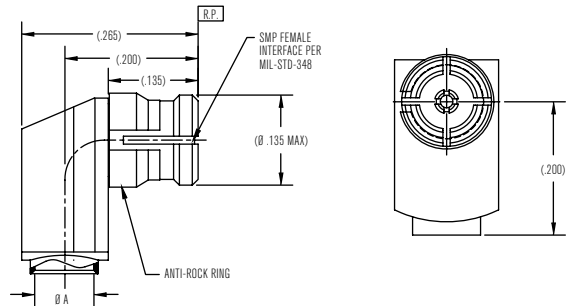

P/N	Ø A	CABLE TYPE
-1CC	.049 MIN	.047 SEMI-RIGID
-2CC	.088 MIN	.085 SEMI-RIGID
-3CC	.049 MIN	.047 MICROPOROUS
-4CC	.088 MIN	.085 MICROPOROUS

SMP Female Right Angle For Semi-Rigid/Semi-Flex Cables, 18 GHz / P659

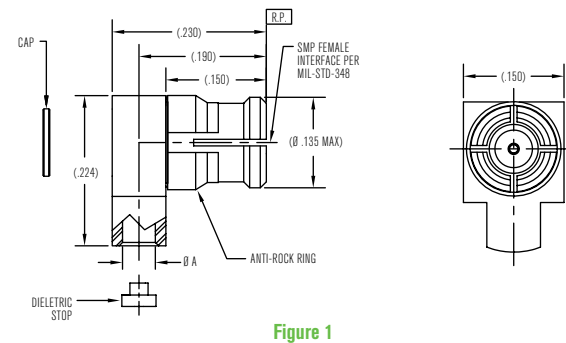

Figure 1

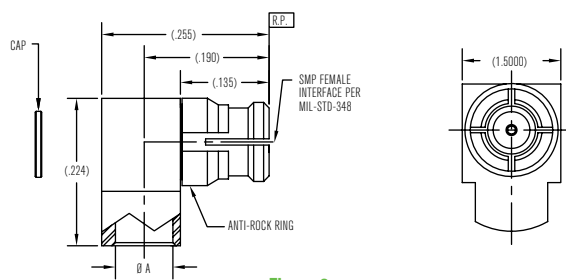
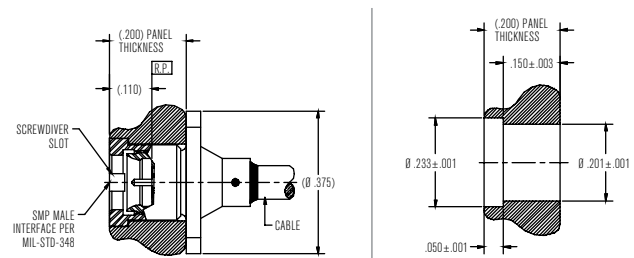
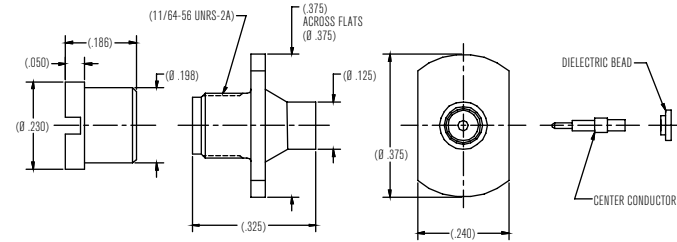

Figure 2

P/N	Ø A	CABLE TYPE	FIGURE
-1CC	.049 MIN	Ø .047 SEMI-RIGID	1
-2CC	.088 MIN	Ø .085 SEMI-RIGID	2
-3CC	.049 MIN	Ø .047 MICROPOROUS	1
-4CC	.088 MIN	Ø .085 MICROPOROUS	2

SMP Male Bulkhead Panel Mount Connector for Semi-Rigid Cables / P662



Installed View

Recommended Panel Hole

P/N	CABLE TYPE	INTERFACE
-1CC	Ø .047 S/R	CATCHER'S MITT
-2CC	Ø .085 S/R	CATCHER'S MITT
-3CC	Ø .047 L/L	CATCHER'S MITT
-4CC	Ø .085 L/L	CATCHER'S MITT
-5CC	Ø .047 S/R	FULL DETENT
-6CC	Ø .085 S/R	FULL DETENT
-7CC	Ø .047 L/L	FULL DETENT
-8CC	Ø .085 L/L	FULL DETENT
-9CC	Ø .047 S/R	LIMITED DETENT
-10CC	Ø .085 S/R	LIMITED DETENT
-11CC	Ø .047 L/L	LIMITED DETENT
-12CC	Ø .085 L/L	LIMITED DETENT
-13CC	Ø .085 S/R	LIMITED DETENT / CATCHER'S MITT

PCB CONNECTORS - THROUGH HOLE BOARD MOUNT

SMP Male PCB Mount to a Straight Termination / P654

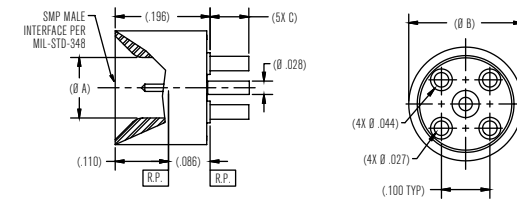

Figure 1

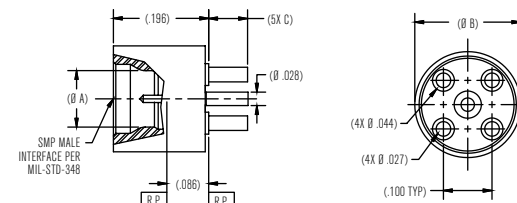
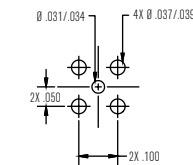

Figure 2



Recommended Mounting Hole Pattern

P/N	INTERFACE	(Ø A)	(Ø B)	(C)	FIGURE
-1CC	LIMITED DETENT	.120	(.218)	.079	2
-2CC	FULL DETENT	.116	(.218)	.079	2
-3CC	SMOOTH BORE	.125	(.218)	.079	2
-4CC	CATCHER'S MITT	.125	(.235)	.079	1
-5CC	FULL DETENT	.116	(.218)	.100	2
-6CC	LIMITED DETENT	.120	(.218)	.100	2
-7CC	SMOOTH BORE	.125	(.218)	.100	2
-8CC	CATCHER'S MITT	.125	(.235)	.100	1
-9CC	FULL DETENT	.116	(.218)	.140	2
-10CC	LIMITED DETENT	.120	(.218)	.140	2
-11CC	SMOOTH BORE	.125	(.218)	.140	2
-12CC	CATCHER'S MITT	.125	(.235)	.140	1

SMP Male Straight PCB Mount - Square Body / P603

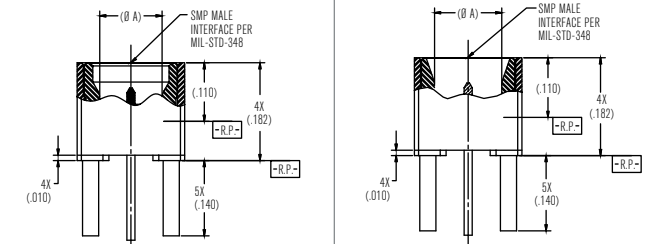
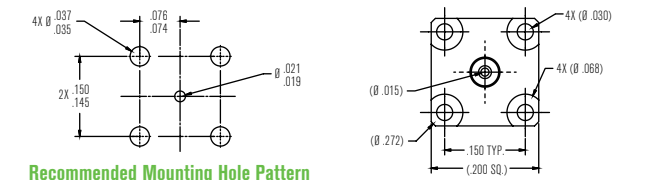

Figure 1

Figure 2



Recommended Mounting Hole Pattern

P/N	INTERFACE	(Ø A)	FIGURE
-1CC	FULL DETENT	.116	1
-2CC	LIMITED DETENT	.120	1
-3CC	SMOOTH BORE	.125	1
-4CC	CATCHER'S MITT	.125	2

SMP Male Right Angle PCB Mount / P646

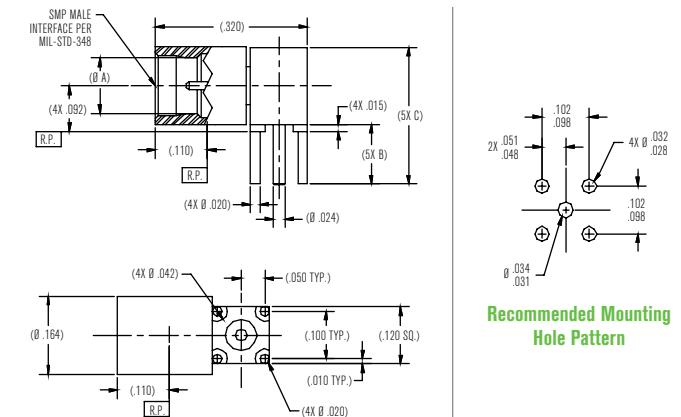

Recommended Mounting Hole Pattern

P/N	INTERFACE	(Ø A)	(Ø B)	(C)
-1CC	FULL DETENT	.116	.125	.287
-2CC	FULL DETENT	.116	.115	.297
-3CC	FULL DETENT	.116	.155	.337

SMP Configurations

PCB CONNECTORS - SURFACE MOUNT

SMP Shroud Solder-in Surface Mount - Short Body / P677

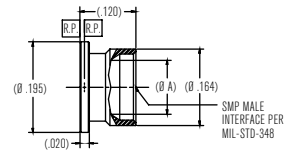

P/N	INTERFACE	(Ø A)
-1	FULL DETENT	.116
-2	LIMITED DETENT	.120
-3	SMOOTH BORE	.125

SMP Male Straight Surface Mount / P703

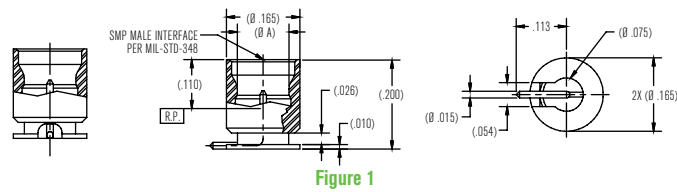

Figure 1

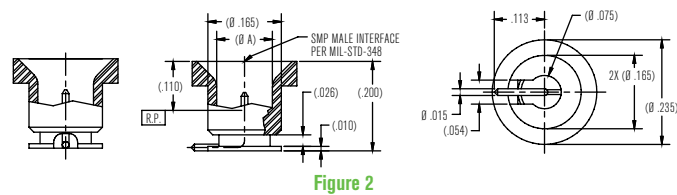
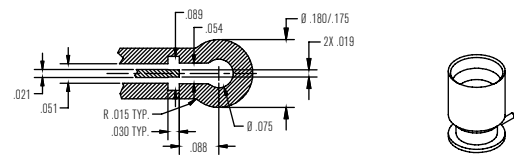

Figure 2



Mounting Hole Pattern

Dimensions shown are for Rogers 4350 PCB Material. These dimensions may vary depending on PCB material used.

P/N	INTERFACE	(Ø A)	FIGURE
-1CC	FULL DETENT	(.116)	1
-2CC	LIMITED DETENT	(.120)	1
-3CC	SMOOTH BORE	(.125)	1
-4CC	CATCHER'S MITT	(.125)	2

SMP Male Straight to Surface Mount with Posts / P797

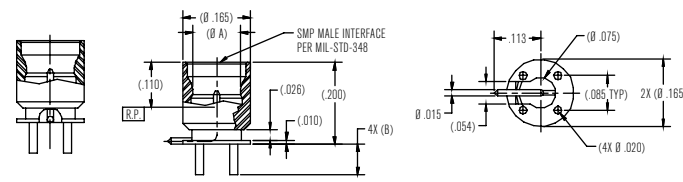

Figure 1

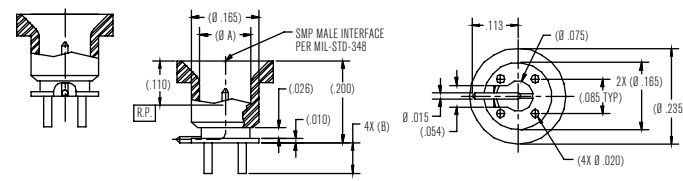
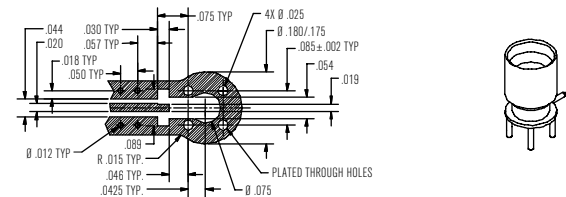

Figure 2



Mounting Hole Pattern

Dimensions shown are for Rogers 4350 PCB Material. These dimensions may vary depending on PCB material used.

P/N	INTERFACE	(Ø A)	(B)	FIGURE
-1CC	FULL DETENT	(.116)	.075	1
-2CC	LIMITED DETENT	(.120)	.075	1
-3CC	SMOOTH BORE	(.125)	.075	1
-4CC	CATCHER'S MITT	(.125)	.075	2
-5CC	FULL DETENT	(.116)	.140	1
-6CC	LIMITED DETENT	(.120)	.140	1
-7CC	SMOOTH BORE	(.125)	.140	1
-8CC	CATCHER'S MITT	(.125)	.140	2

SMP Male Straight Surface Mount / P839

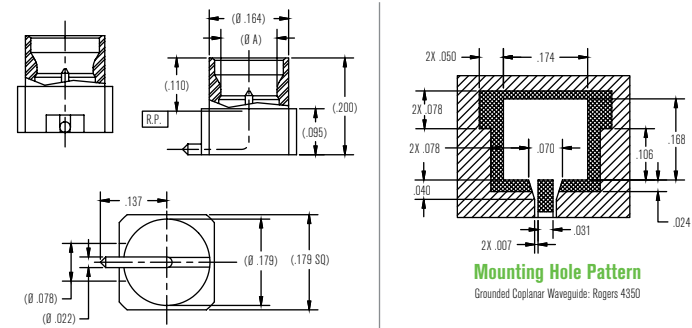

Mounting Hole Pattern

Grounded Coplanar Waveguide: Rogers 4350

P/N	INTERFACE	(Ø A)
-1CC	FULL DETENT	.116
-2CC	LIMITED DETENT	.120
-3CC	SMOOTH BORE	.125

PCB CONNECTORS - EDGE MOUNT

SMP Male Straight Edge Mount Connector / P606

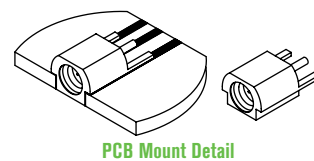
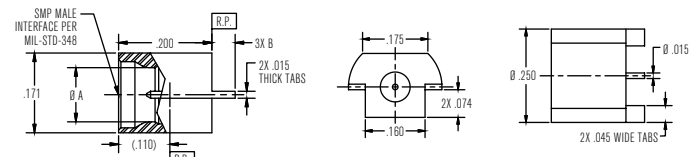

PCB Mount Detail

Recommended PCB Cutout

P/N	INTERFACE	Ø A	B	C
-1CC	FULL DETENT	.116	.090	.095
-2CC	LIMITED DETENT	.120	.090	.095
-3CC	SMOOTH BORE	.125	.090	.095
-4CC	FULL DETENT	.116	.050	.055
-5CC	LIMITED DETENT	.120	.050	.055
-6CC	SMOOTH BORE	.125	.050	.055

SMP Male Straight Edge Mount Connector / P698

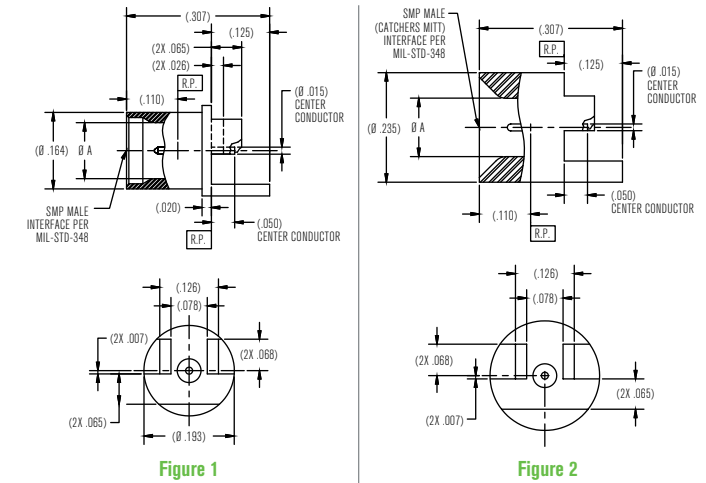
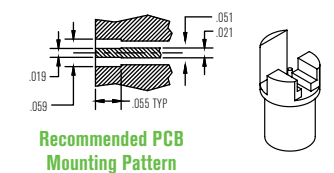

Figure 1

Figure 2



Recommended PCB Mounting Pattern

P/N	INTERFACE	(Ø A)	FIGURE
-1CC	FULL DETENT	(.116)	1
-2CC	LIMITED DETENT	(.120)	1
-3CC	SMOOTH BORE	(.125)	1
-4CC	CATCHER'S MITT	(.125)	2

SHROUDS - FLANGE MOUNT

SMP Shroud - Full Detent Straight 2-Hole Flange Mount / P670

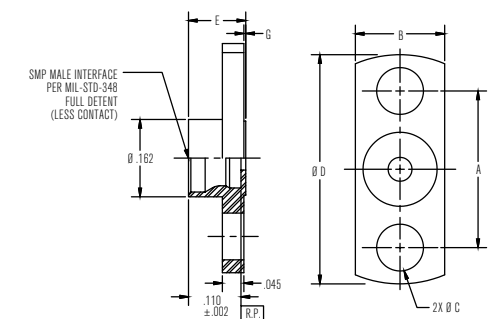

P/N	A	B	Ø C	Ø D	E	F	G
-1SF	.328	.187	.098	.480	.120	.045	.004
-2SF	.481	.223	.102	.625	.120	.045	.002
-3SF	.282	.165	.073	.400	.120	.045	.002
-4SF	.400	.186	.103	.550	.120	.045	.004
-5SF	.282	.165	.073	.400	.120	.045	.005
-6SF	.282	.165	*	.400	.120	.045	.005
-7SF	NR	NR	NR	.625	.120	.075	.003
-8SF	.481	.223	.102	.625	.120	.045	.004
-8	.481	.223	.102	.625	.120	.045	.004
-9SF	.282	.165	.073	.400	.120	.045	.004
-10SF	.328	.187	.098	.480	.120	.045	.005

* 2X #0-80 UNF-2B X Ø .085 X 90° Countersunk

SMP Configurations

SHROUDS - FLANGE MOUNT (CONT.)

SMP Shroud - Limited Detent Straight 2-Hole Flange Mount / P672

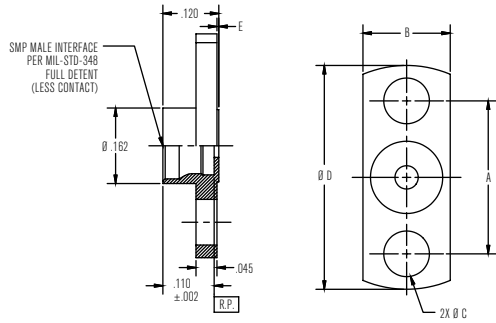

P/N	A	B	Ø C	Ø D	E
-1SF	.328	.187	.098	.480	.004
-2SF	.481	.223	.102	.625	.004
-3SF	.282	.165	.073	.400	.002
-4SF	.400	.186	.103	.550	.004

SMP Shroud - Smooth bore Straight 2-Hole Flange Mount / P673

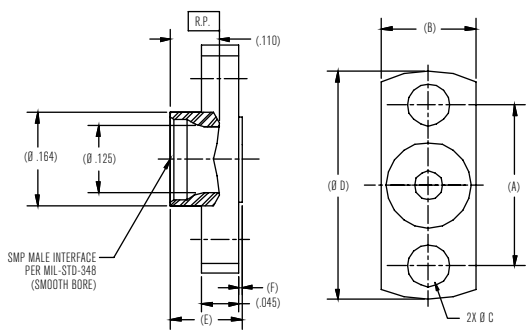

P/N	(A)	(B)	(Ø C)	(Ø D)	(E)	(F)
-1SF	.328	.187	.098	.480	.120	.004
-2SF	.481	.223	.102	.625	.120	.002
-3SF	.282	.165	.073	.400	.120	.002

SHROUDS - THREAD-IN

SMP Shroud - Thread-In / P676

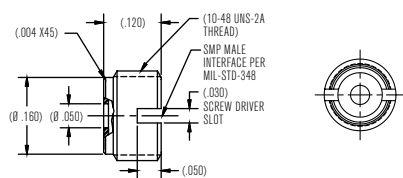

Figure 1

SMP Shroud - Thread-In / P676 (Continued)

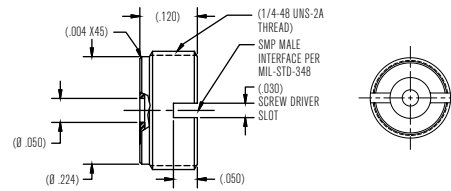
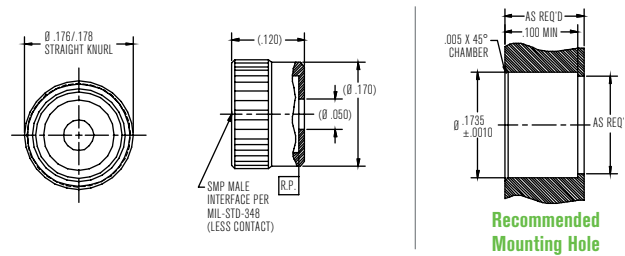

Figure 2

P/N	INTERFACE	FIGURE
-1SF	FULL DETENT	1
-2SF	LIMITED DETENT	1
-3SF	SMOOTH BORE	1
-4SF	CATCHER'S MITT	2

SHROUDS - PRESS-IN

SMP Press-In Shroud / P675



P/N	INTERFACE
-1SF	FULL DETENT
-2SF	LIMITED DETENT
-3SF	SMOOTH BORE

SMP Press-In Shroud - Short Body / P769

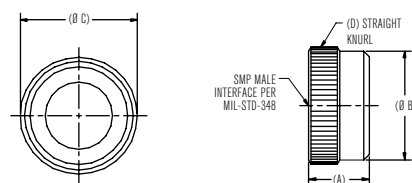

P/N	(A)	(Ø B)	(Ø C)	(D)
-1SF	.080	.143	.154	50P
-2SF	.120	.163	.174	50P
-3SF	.115	.163	.184	128P

SHROUDS - FIELD-REPLACEABLE

SMP (male) 2-hole flange mount (accepts 0.012" pin) / P836

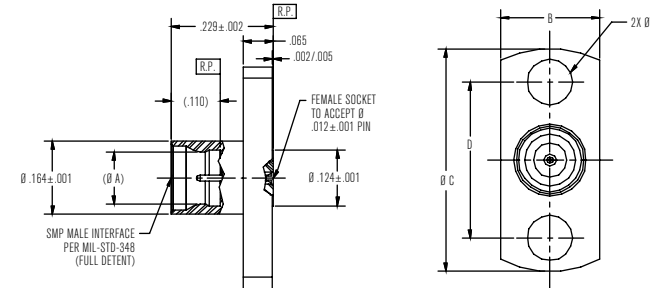

P/N	INTERFACE	A	B	Ø C	D	Ø E
-1CC	FULL DETENT	(.116)				
-1CCSF	FULL DETENT	(.116)				
-2CC	LIMITED DETENT	(.120)	.165	.625	.481 ±.002	.078
-2CCSF	LIMITED DETENT	(.120)	.165	.625	.481 ±.002	.078
-3CC	SMOOTH BORE	(.125)				
-3CCSF	SMOOTH BORE	(.125)				
-4CC	FULL DETENT	(.116)				
-4CCSF	FULL DETENT	(.116)				
-5CC	LIMITED DETENT	(.120)	.223	.625	.481 ±.002	.078
-5CCSF	LIMITED DETENT	(.120)	.223	.625	.481 ±.002	.078
-6CC	SMOOTH BORE	(.125)				
-6CCSF	SMOOTH BORE	(.125)				
-7CC	FULL DETENT	(.116)				
-7CCSF	FULL DETENT	(.116)				
-8CC	LIMITED DETENT	(.120)	.223	.485	.350 ±.002	.102
-8CCSF	LIMITED DETENT	(.120)	.223	.485	.350 ±.002	.102
-9CC	SMOOTH BORE	(.125)				
-9CCSF	SMOOTH BORE	(.125)				

HERMETICS

SMP Male Hermetic Shroud - Short Body / P680

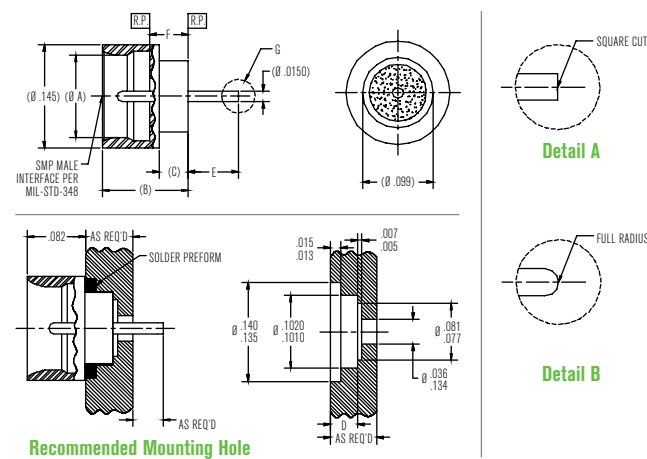

SMP Male Hermetic Shroud - Short Body / P680 (Continued)

P/N	INTERFACE	(Ø A)	(B)	(C)	D	E	F	G
-1CC	FULL DETENT	.116	.120	.040	.037/.039	.050	.050 ±.001	SEE DETAIL A
-2CC	LIMITED DETENT	.120	.120	.040	.037/.039	.050	.050 ±.001	
-3CC	SMOOTH BORE	.125	.120	.040	.037/.039	.050	.050 ±.001	
-4CC	FULL DETENT	.116	.120	.040	.037/.039	.050	.050 ±.001	
-5CC	LIMITED DETENT	.120	.120	.040	.037/.039	.050	.050 ±.001	
-6CC	SMOOTH BORE	.125	.120	.040	.037/.039	.050	.050 ±.001	
-10CC	FULL DETENT	.116	.120	.040	.037/.039	.070	.050 ±.001	
-11CC	LIMITED DETENT	.120	.120	.040	.037/.039	.070	.050 ±.001	
-12CC	SMOOTH BORE	.125	.120	.040	.037/.039	.070	.050 ±.001	
-13CC	FULL DETENT	.116	.120	.040	.037/.039	.090	.050 ±.001	
-14CC	LIMITED DETENT	.120	.120	.040	.037/.039	.090	.050 ±.001	SEE DETAIL B
-15CC	SMOOTH BORE	.125	.120	.040	.037/.039	.090	.050 ±.001	
-22CC	FULL DETENT	.116	.120	.040	.037/.039	.050	.050 ±.001	
-23CC	LIMITED DETENT	.120	.120	.040	.037/.039	.050	.050 ±.001	
-24CC	SMOOTH BORE	.125	.120	.040	.037/.039	.050	.050 ±.001	
-25CC	FULL DETENT	.116	.120	.040	.037/.039	.070	.050 ±.001	
-26CC	LIMITED DETENT	.120	.120	.040	.037/.039	.070	.050 ±.001	
-27CC	SMOOTH BORE	.125	.120	.040	.037/.039	.070	.050 ±.001	
-28CC	FULL DETENT	.116	.120	.040	.037/.039	.090	.050 ±.001	
-29CC	LIMITED DETENT	.120	.120	.040	.037/.039	.090	.050 ±.001	
-30CC	SMOOTH BORE	.125	.120	.040	.037/.039	.090	.050 ±.001	

SMP Male Hermetic Shroud / P682

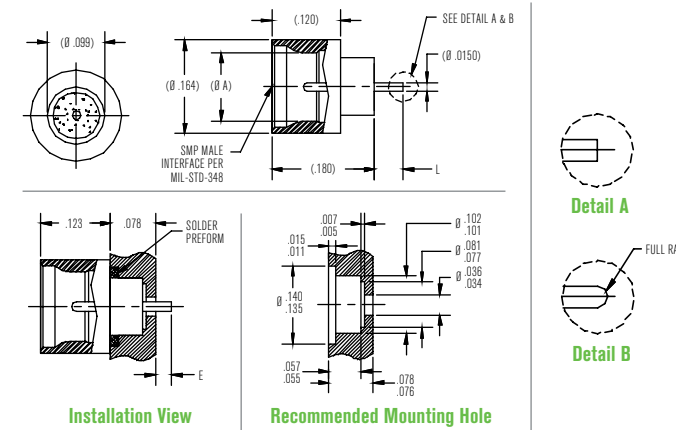

P/N	INTERFACE	(Ø A)	L	E	DETAIL
-1CC	FULL DETENT	.116	.050	.030	A
-2CC	LIMITED DETENT	.120	.050	.030	A
-3CC	SMOOTH BORE	.125	.050	.030	A
-4CC	FULL DETENT	.116	.240	.220	B
-5CC	LIMITED DETENT	.120	.240	.220	B
-6CC	SMOOTH BORE	.125	.240	.220	B

SMP Configurations

HERMETICS (CONT.)

SMP Male Hermetic Thread-In with Mounting Nut / P683

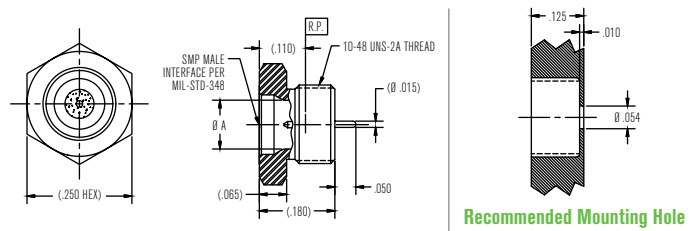

Recommended Mounting Hole

P/N	INTERFACE	(Ø A)
-1CC	FULL DETENT	(.116)
-2CC	LIMITED DETENT	(.120)
-3CC	SMOOTH BORE	(.125)

SMP Male Hermetic Thread-In / P761

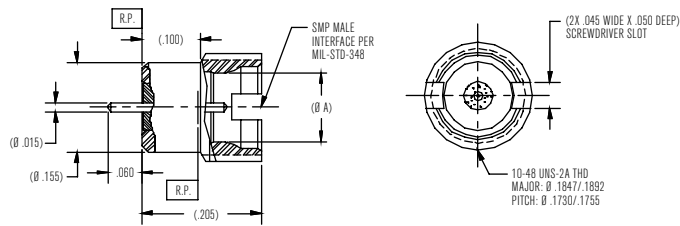

P/N	INTERFACE	(Ø A)
-1CC	LIMITED DETENT	(.120)
-2CC	FULL DETENT	(.116)

OPEN/SHORTS/LOADS

SMP Female 50 Ohm Termination / P918

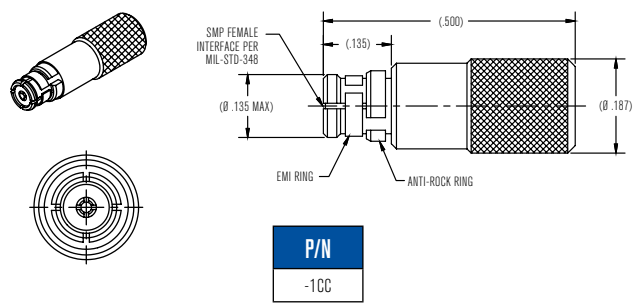

P/N
-1CC

SMP Male 50 Ohm Termination / P919

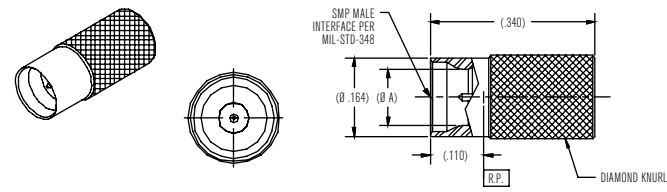

P/N	INTERFACE	(Ø A)
-1CCSF	FULL DETENT	.116
-2CCSF	LIMITED DETENT	.120
-3CCSF	SMOOTH BORE	.125

SMP Female Short / P930-1CC

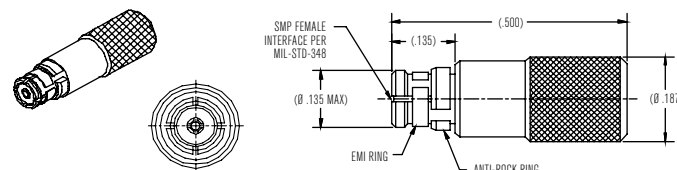

SMP Female Open / P931-1

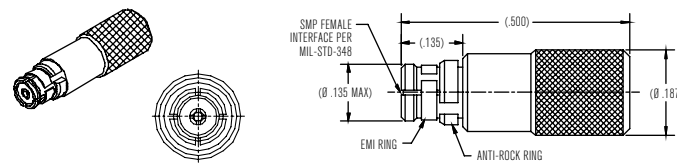

BULLETS/ADAPTERS

SMP Female to SMP Female Bullet / P617

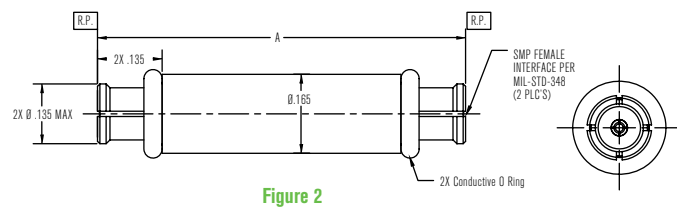
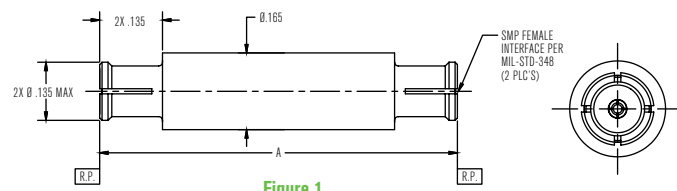

SMP Female to SMP Female Bullet / P617 (Continued)

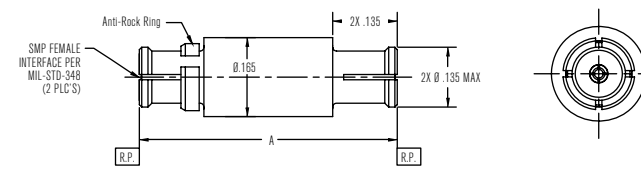

Figure 3

P/N	A	FIGURE
-1CC	.768/.770	1
-2CC	.850/.852	1
-3CC	1.365/1.367	1
-4CC	.439/.441	2
-5CC	.768/.770	2

SMP Female to SMP Female Bullet - Short Body / P650

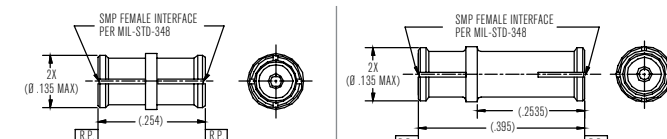

Figure 1

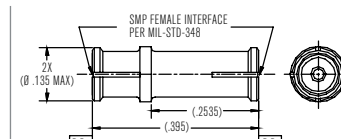

Figure 3

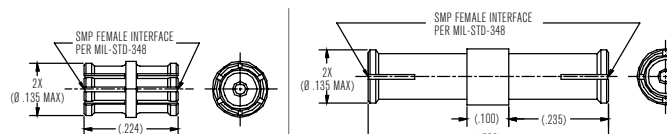

Figure 2

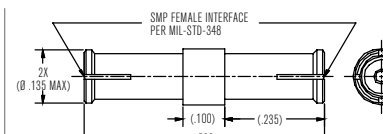
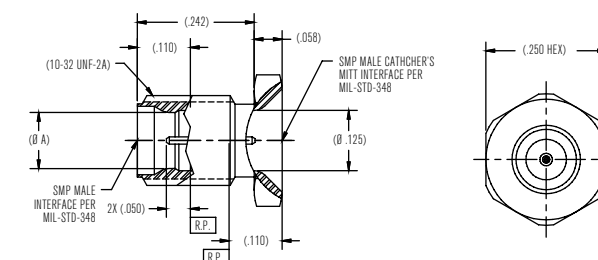

Figure 4

P/N	FIGURE
-1CC	1
-2CC	2

P/N	FIGURE
-3CC	3
-4CC	4

SMP Male Bulkhead to SMP Male Catcher's Mitt / P912



P/N	INTERFACE	(Ø A)
-1CCSF	FULL DETENT	.116
-2CCSF	LIMITED DETENT	.120
-3CCSF	SMOOTH BORE	.125

SMP Male to SMP Female Adapter / P914

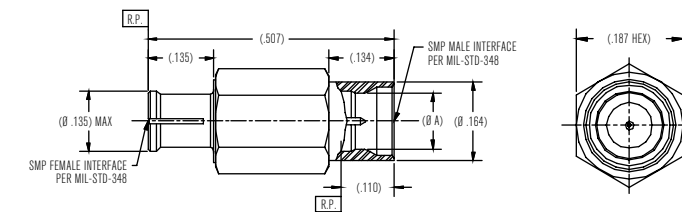

P/N	INTERFACE	(Ø A)
-1CCSF	FULL DETENT	.116
-2CCSF	LIMITED DETENT	.120
-3CCSF	SMOOTH BORE	.125

SMP Male to SMP Female Catcher's Mitt / P916

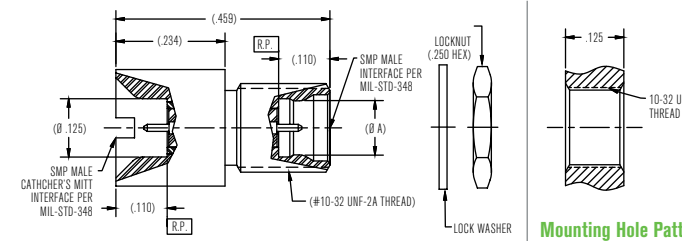

P/N	INTERFACE	(Ø A)
-1CCSF	FULL DETENT	.116
-2CCSF	LIMITED DETENT	.120
-3CCSF	SMOOTH BORE	.125

SMP Female to SMP Female Spring Loaded Bullet / P922

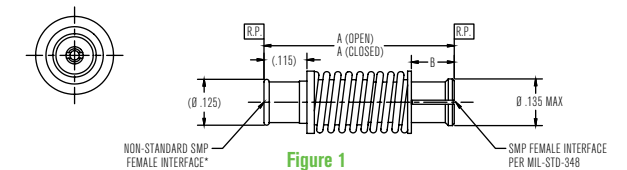

Figure 1

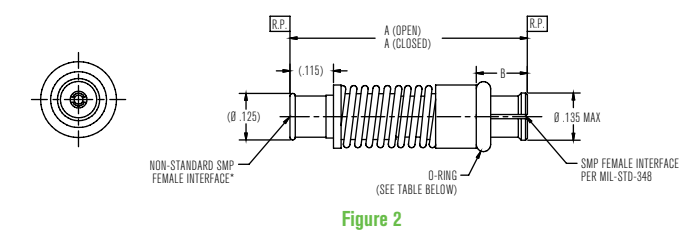

Figure 2

* FOR USE WITH SMOOTH BORE AND CATCHER'S MITT INTERFACES ONLY

P/N	FIGURE	A (OPEN)	A (CLOSED)	B	O-RING	SPRING PRE-LOAD	SPRING RATE
-2CC	1	.510	.460	.115	NOT REQ'D	1.95 LBS	15.0 LBS/IN
-3CC	2	.745	.695	.115	NOT REQ'D	1.21 LBS	5.5 LBS/IN
-4CC	2	.660	.610	.135	REQ'D	1.21 LBS	5.5 LBS/IN

Ordering Information

Configuration		Part Number*	Description	Options
Cable Connectors	For Flexible Cables	P657	SMP (female) straight conn for flexible cables	Available for different flexible cables (see figure)
		P600	SMP (female) rt angle conn for flexible cables, 18 GHz	
		P601	SMP (female) rt angle conn for flexible cables, 26.5 GHz	
		P663	SMP (male) straight panel mount conn for flexible cables	
	For Semi-rigid & Semi-flex Cables	P651	SMP (female) straight conn for semi-rigid and semi-flex cables	0.047" & 0.085" cable versions available (see figure)
		P658	SMP (female) float mount conn for semi-rigid and semi-flex cables	
		P652	SMP (female) rt. angle for semi-rigid/semi-flex cables, 12 GHz	
		P655	SMP (female) rt. angle for semi-rigid/semi-flex cables, 26.5 GHz	
		P659	SMP (female) rt. angle for semi-rigid/semi-flex cables, 18 GHz	
		P662	SMP (male) bulkhead panel mount conn for semi-rigid cables	
PCB Connectors	Through hole Board Mount	P654	SMP (male) PCB mount to a straight termination	Different heights and detents available (see figure)
		P603	SMP (male) straight PCB mount - square body	
		P646	SMP (male) rt. angle PCB mount	
	Surface Mount	P677	SMP shroud solder-in surface mount - short body	Different detents available (see figure)
		P703	SMP (male) straight surface mount	
		P797	SMP (male) straight to surface mount w/ posts	
		P839	SMP (male) straight surface mount	
		P606	SMP (male) straight edge mount connector	
	Edge Mount	P698	SMP (male) straight edge mount connector	
Shrouds	Flange Mount	P670	SMP shroud - full detent straight 2-hole flange mount	Different flange dimensions available (see figure)
		P672	SMP shroud - limited detent straight 2-hole flange mount	
		P673	SMP shroud - smooth bore straight 2-hole flange mount	
	Thread-in	P676	SMP shroud - Thread-in	
	Press-in	P675	SMP press-in shroud	Different detents available (see figure)
		P769	SMP press-in shroud - Short Body	
	Field-replaceable	P836	SMP (male) 2-hole flange mount (accepts 0.012" pin)	Narrow flange version available (see figure)
Hermetics		P680	SMP (male) hermetic shroud - Short Body	Different detents and pin styles available (see figure)
		P682	SMP (male) hermetic shroud	
		P683	SMP (male) hermetic thread-in w/ mounting nut	
		P761	SMP (male) hermetic thread-in	
Opens, Shorts, Loads		P918	SMP (female) 50 Ohm termination	
		P919	SMP (male) 50 Ohm termination	
		P930-1CC+	SMP (female) Short	
		P931-1+	SMP (female) Open	
Bullets/Adapters		P617	SMP (female) to SMP (female) bullet	Different lengths available (see figure)
		P650	SMP (female) to SMP (female) bullet - short body	
		P912	SMP (male) bulkhead to SMP (male) catcher's mitt	Different detents available (see figure)
		P914	SMP (male) to SMP (female) adapter	
		P916	SMP (male) to SMP (male) catcher's mitt	
		P922	SMP (female) to SMP (female) spring loaded bullet	
			See chart for available lengths	

* All parts have a suffix. Please refer to figures for more information

* These part numbers don't require an additional suffix