

Features

- High Isolation (35 dB @ 0.9 GHz)
- Low Insertion Loss (0.5 dB @ 0.9 GHz)
- Low DC Power Consumption

Description

The ASC02R2-12 is a low cost IC FET SPDT reflective general purpose switch in a plastic SOIC-8 package for commercial low cost, low power applications. The switch operates with -5, 0 V or 0, +5 V when “floated” as shown on the following page.

SOIC-8

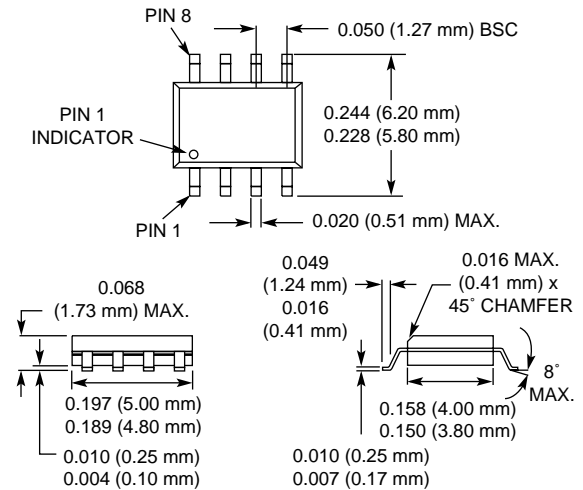

Electrical Specifications at 25°C (0, -5 V)

Parameter ¹	Frequency ²	Min.	Typ.	Max.	Unit
Insertion Loss ³	DC–0.1 GHz		0.4	0.5	dB
	DC–0.5 GHz		0.5	0.6	dB
	DC–1.0 GHz		0.6	0.7	dB
	DC–2.0 GHz		0.8	1.0	dB
	DC–2.5 GHz		1.0	1.1	dB
Isolation	DC–0.1 GHz	55	60		dB
	DC–0.5 GHz	40	42		dB
	DC–1.0 GHz	30	33		dB
	DC–2.0 GHz	20	25		dB
	DC–2.5 GHz	20	22		dB
VSWR ⁴	DC–2.0 GHz		1.2:1	1.4:1	
	DC–2.5 GHz		1.5:1	1.7:1	

Operating Characteristics at 25°C (0, -5 V)

Parameter	Condition	Frequency	Min.	Typ.	Max.	Unit
Switching Characteristics ⁵	Rise, Fall (10/90% or 90/10% RF)			3		ns
	On, Off (50% CTL to 90/10% RF)			6		ns
	Video Feedthru			15		mV
Input Power for 1 dB Compression		0.5–2.0 GHz		+22		dBm
Intermodulation Intercept Point (IP3)	For Two-tone Input Power +13 dBm	0.5–2.0 GHz		40		dBm
Control Voltages	$V_{Low} = 0$ to -0.2 V @ 20 μ A Max. $V_{High} = -5$ @ 20 μ A to -8 V @ 200 μ A Max.					

1. All measurements made in a 50 Ω system, unless otherwise specified.
2. DC = 300 kHz.
3. Insertion loss changes by 0.003 dB/°C.
4. Insertion loss state.
5. Video feedthru measured with 1 ns risetime pulse and 500 MHz bandwidth.

Typical Performance Data (0, -5 V)

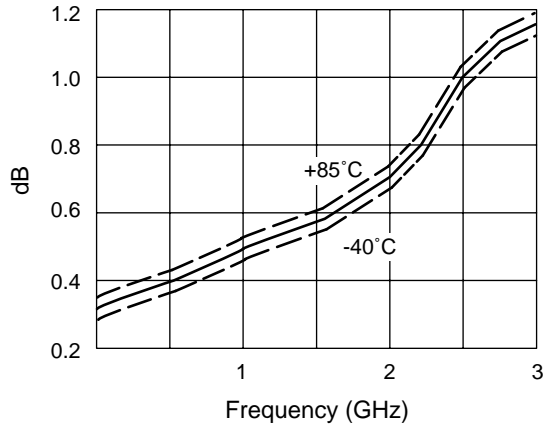

Insertion Loss vs. Frequency

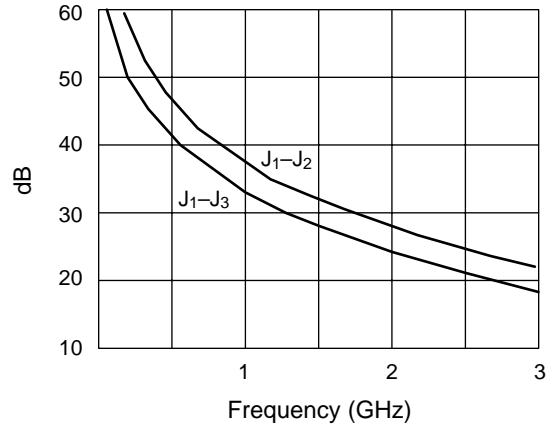

Isolation vs. Frequency

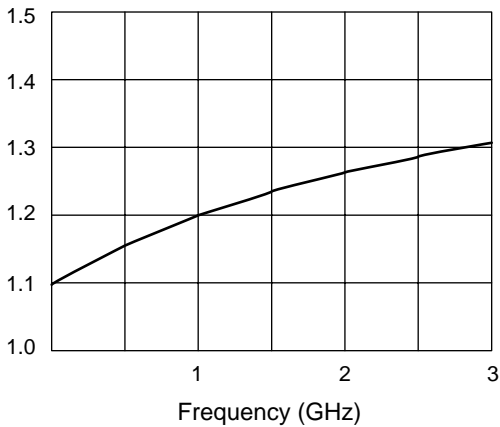

VSWR vs. Frequency

Truth Table

Negative Operation

V ₁	V ₂	J ₁ -J ₂	J ₁ -J ₃
0	-5	Isolation	Insertion Loss
-5	0	Insertion Loss	Isolation

Positive Operation¹

V ₁	V ₂	J ₁ -J ₂	J ₁ -J ₃
V _{High}	0	Isolation	Insertion Loss
0	V _{High}	Insertion Loss	Isolation

V_{High} = +5 to +8 V (V_S = V_{High} ± 0.2 V).

1. Refer to Application Notes for further information.

Absolute Maximum Ratings

Characteristic	Value
RF Input Power	2 W > 500 MHz 0/-8 V 0.5 W @ 50 MHz 0/-8 V
Control Voltage	+0.2 V, -8 V
Operating Temperature	-40°C to +85°C
Storage Temperature	-65°C to +150°C
Θ _{JC}	25°C/W

Note: Exceeding these parameters may cause irreversible damage.

Pin Out

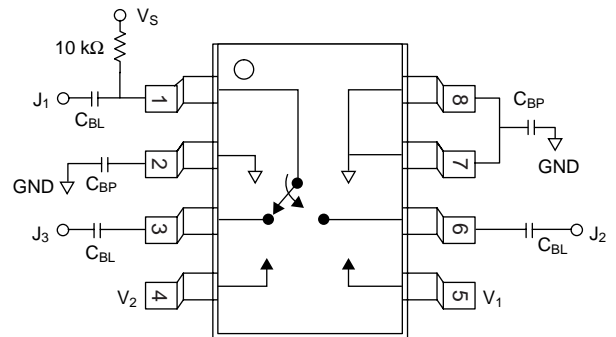

External components shown are for positive voltage operation only. C_{BL} = 100 pF, C_{BP} = 1000 pF. Capacitance values chosen for operation >500 MHz.