

STRAIGHT PLUG CRIMP TYPE

R125.072.000

CABLE 2.6/50

Series : SMA

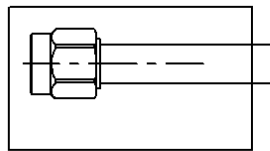
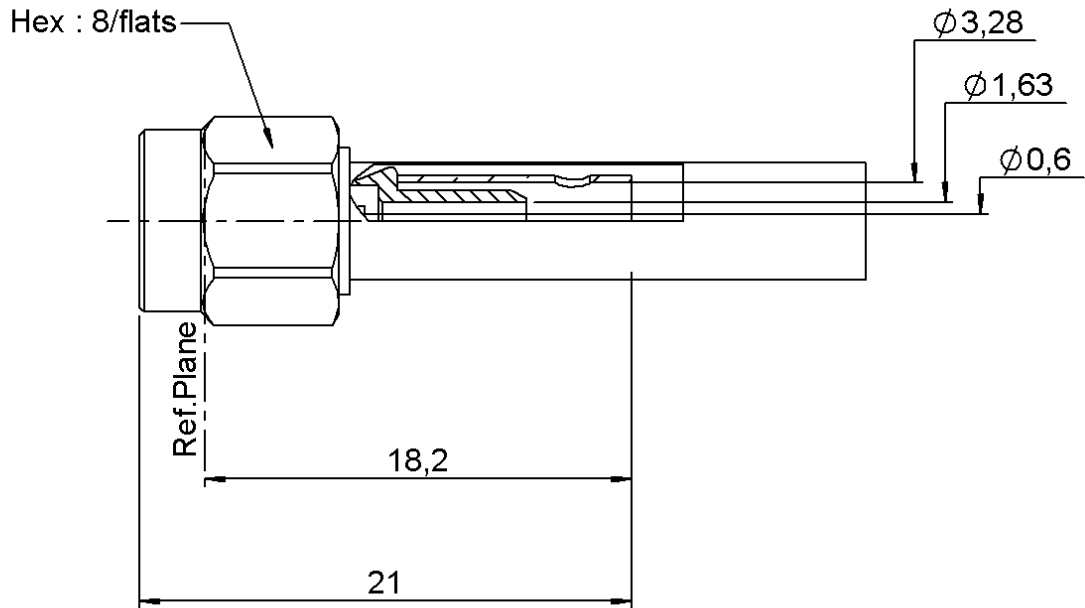

Scale : 1/1

All dimensions are in mm.

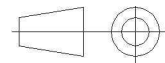

COMPONENTS	MATERIALS	PLATING (µm)
BODY	STAINLESS STEEL	GOLD 0.5 OVER NICKEL 2
CENTER CONTACT	BRASS	.GOLD 1.3 OVER NICKEL 2
OUTER CONTACT	-	-
INSULATOR	PTFE	-
GASKET	SILICONE RUBBER	-
OTHERS PARTS	STAINLESS STEEL	GOLD 0.5 OVER NICKEL 2
-	-	-
-	-	-

Issue : 0742 C

In the effort to improve our products, we reserve the right to make changes judged to be necessary.



RADIALL®

STRAIGHT PLUG CRIMP TYPE

R125.072.000

CABLE 2.6/50

Series : SMA

PACKAGING

Standard	Unit	Other
100	'W' option	Contact us

SPECIFICATION

LEA COCSMA6-201 1 00

ELECTRICAL CHARACTERISTICS

Impedance		50 Ω
Frequency		0-12.4 GHz
VSWR	1.15 +	0,0200 x F(GHz) Maxi
Insertion loss		0.06 √F(GHz) dB Maxi
RF leakage	- (60 - F(GHz)) dB Maxi
Voltage rating		250 Veff Maxi
Dielectric withstanding voltage		750 Veff mini
Insulation resistance		5000 MΩ mini

CABLE ASSEMBLY

Stripping	a	b	c	d	e	f
mm	2,00	6,00	9,50	0,00	7,50	0,00

Assembly instruction : **Crimp 01**

Recommended cable(s)

RG 316
KX 22A
RG 188

Characteristics indicated on this data sheet are those that can be achieved with the highest performance cable. Intrinsic limitations of the cable may diminish the performance of the assembly

Cable retention

- pull off **90** N mini
- torque **NA** N.cm

MECHANICAL CHARACTERISTICS

Center contact retention		
Axial force – Mating end	NA	N mini
Axial force – Opposite end	27	N mini
Torque	NA	N.cm mini

TOOLING

Part Number	Description	Hexagon
.	.	.
R282.293.000	CRIMPING TOOL M22520/5-01	-
R282.235.003	CRIMPING DIES	3.25
. Or - (ou)		
R282.211.000	CRIMPING TOOL	3.25

Recommended torque		
Mating	100	N.cm
Panel nut	NA	N.cm
Clamp nut	NA	N.cm
A/F clamp nut	0,0000	mm

Mating life	500	Cycles mini
Weight	2,9130	g

OTHER CHARACTERISTICS

-

ENVIRONMENTAL

Operating temperature	-65/+165	° C
Hermetic seal	NA	Atm.cm3/s
Panel leakage	NA	

Issue : 0742 C

In the effort to improve our products, we reserve the right to make changes judged to be necessary.

